

English



Fujitsu Software

BS2000 OS DX System Installation

User Guide

Valid for:
BS2000 V21.0A

Edition June 2023

Comments... Suggestions... Corrections...

The User Documentation Department would like to know your opinion on this manual. Your feedback helps us to optimize our documentation to suit your individual needs.

Feel free to send us your comments by e-mail to: bs2000.info@fujitsu.com.

Certified documentation according to DIN EN ISO 9001:2015

To ensure a consistently high quality standard and user-friendliness, this documentation was created to meet the regulations of a quality management system which complies with the requirements of the standard DIN EN ISO 9001:2015.

Copyright and Trademarks

Copyright © 2025 Fujitsu

All rights reserved.

Delivery subject to availability; right of technical modifications reserved.

All hardware and software names used are trademarks of their respective manufacturers.

Table of Contents

- System Installation** 5
- 1 Preface** 6
 - 1.1 Objectives and target groups of this manual** 7
 - 1.2 Summary of contents** 8
 - 1.3 Changes since the last edition of the manual** 10
 - 1.4 Notational conventions** 11
- 2 Initial installation** 12
- 3 Version changeover** 14
- 4 System generation** 16
 - 4.1 System generation on Server Unit x86** 17
 - 4.2 System generation on Server Unit /390** 18
 - 4.2.1 Generating the I/O configuration data (IOCF) with IOGEN 19
 - 4.2.1.1 Starting IOGEN 20
 - 4.2.1.2 IOGEN statements 22
 - 4.2.1.3 IOGEN messages 23
 - 4.2.1.4 IOGEN logs 24
 - 4.2.1.5 Generating the IOCF via IOGEN 25
 - 4.2.2 Generating the I/O configuration data (IOCF) with SE Manager 26
 - 4.2.3 IOCF terminology 27
 - 4.2.4 Fibre Channel 29
 - 4.2.5 Rules for generating the I/O configuration data 30
 - 4.2.5.1 I/O configuration 31
 - 4.2.5.2 Configuration for the hardware test 33
 - 4.2.5.3 Configuration of the Management Unit (MU) 34
 - 4.2.5.4 Network configuration 38
 - 4.2.5.5 Disk device configuration 40
 - 4.2.5.6 Creating device addresses 41
 - 4.2.5.7 General conditions for hardware generation 43
 - 4.2.6 Generation example (IOGEN statements) 46
 - 4.2.7 Generation example for FastDPAV 49
 - 4.2.8 An IOGEN description for two or more Server Units 50
 - 4.2.9 Customizing the BS2000 Control System 53
 - 4.2.10 Statements for IOGEN 54
 - 4.2.10.1 CHN - Define channel 56
 - 4.2.10.2 CPGOPT - Define generation options for IOGEN 57
 - 4.2.10.3 CPU - Define CPU 58
 - 4.2.10.4 CTL - Define controller 59

4.2.10.5 DVC - Define device	61
4.2.10.6 END - Terminate IOGEN statements	63
4.2.10.7 GEN - Define program name	64
4.2.10.8 IOCFID - Define header text for IOCF	65
4.2.10.9 SYSFILE - Change assignment of input medium	66
4.2.10.10 * Insert comments	67
5 Installation services	68
5.1 Disk organization with pubsets	69
5.2 The software product SIR	76
6 Handling important system files	77
6.1 Startup files	78
6.2 File catalog TSOSCAT	81
6.3 Paging area	82
6.4 SYSEAM files	83
6.5 User catalog	84
7 Appendix	85
7.1 Disk organization	86
7.2 Device type table	88
7.3 Volume type table	90
7.4 Allocation table: mnemonic name - device number	92
8 Related publications	101

System Installation

1 Preface

System installation of the operating system BS2000 OSD/BC V11.0 on SE servers covers all the activities involved in preparing an executable BS2000 operating system that is geared to the current hardware configuration of the Server Unit.

These activities include:

- providing the necessary volumes (disks)
- reading in / installing all relevant files
- generating installation-specific objects (e.g. IO configuration file)

System installation thus creates the prerequisites for initialization of a BS2000 operating system for the Server Unit concerned.

The system initialization itself is no longer part of system installation; it is described in the “Introduction to System Administration” [4].

Information about the various hardware components, interfaces and maximum values for the SE servers is available online: <https://www.fujitsu.com/emeia/products/> > Servers > BS2000 Mainframes > Fujitsu Server BS2000 > “Model selection”.

Information about key figures and performance data of the hardware and software components is provided in the Performance Handbook [3].

1.1 Objectives and target groups of this manual

This manual deals with the topics required to enable the BS2000 operating system to be installed on the existing hardware configuration:

It is intended for use by persons who are responsible for the installation of BS2000 systems or who require information about the various generation types and facilities.

1.2 Summary of contents

This manual begins with an introduction of the standard installation procedures “initial installation” and “version changeover”. These procedures consist of various installation steps.

These steps, which can also be used separately, are then explained in terms of practical operation with installation products (chapters “System generation” and “Installation services”).

Not described in this manual is the installation of specific objects such as REP loaders, message files, network configuration, etc. as it is dealt with in other manuals.

Architecture of the SE servers

A Fujitsu BS2000 server of the SE series (for short: SE server) consists of the following components in its maximum configuration:

- Server Units (SU /390 and SU x86)
- Application Units (AU)
- Peripherals (storage)
- Management Unit (MU) with SE Manager
- Net Unit, for SU /390 with HNC

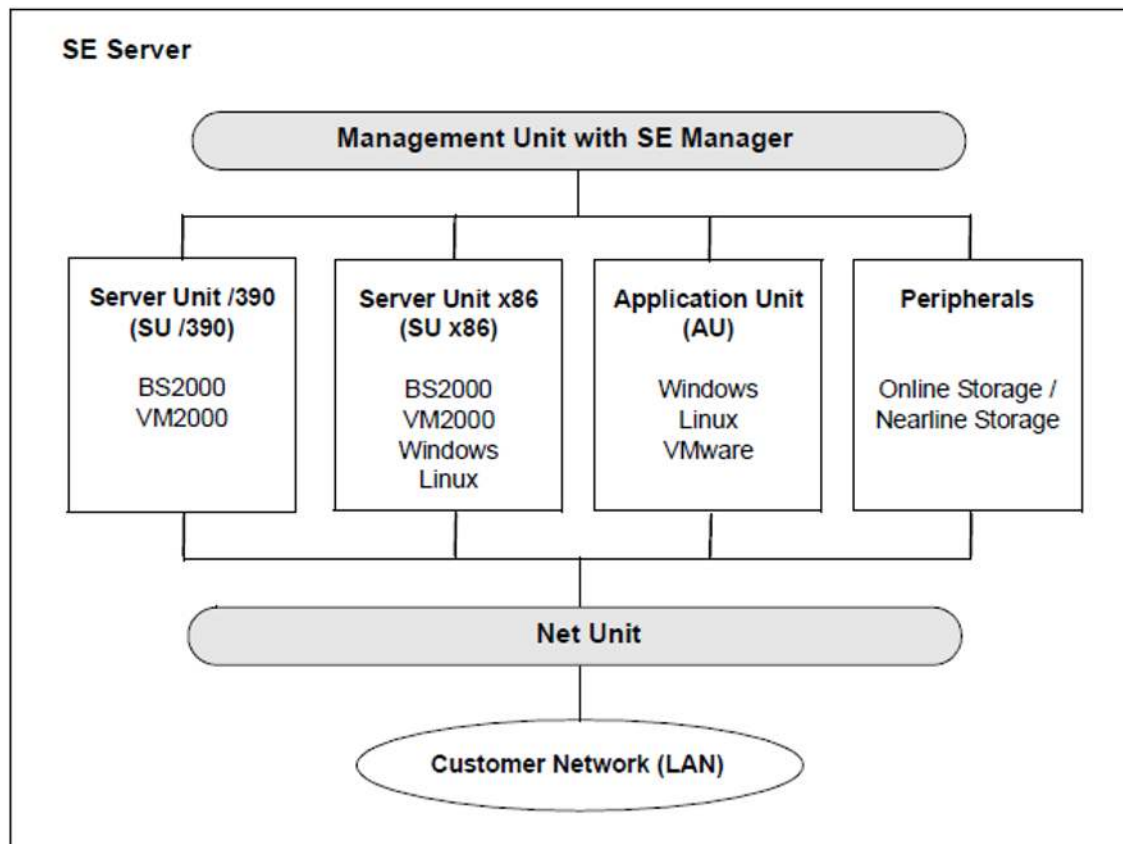

Figure 1: Architecture of the SE servers

With the SE Manager you can operate and manage all components of the SE server centrally from the Management Unit. The SE Manager offers a user-friendly, web-based user interface for this purpose.

In addition to the maximum configuration, variants are also offered which do not contain all Units.

Operation of the SE Manager is described in the online help for the SE Manager and in the “Operation and Administration” manual [5].

The Net Unit, for SU /390 with High-Speed Network Connect (HNC), offers highest performance and security for internal communication in an SE server and for the connection to customer networks (LAN).

The BS2000 operating system in the released versions serves the Server Unit /390 (/390 server) and the Server Unit x86 (x86 server).

i Further configuration levels of the Server Units may be released at some point in the future. Watch out for product announcements and release information.

The `/SHOW-INSTALLATION-PATH INSTALLATION-UNIT=<product>` command shows the user ID under which the product's files are stored.

Additional product information

Current information, version and hardware dependencies and instructions for installing and using a product version are contained in the associated Release Notice. These Release Notices are available online at <http://bs2manuals.ts.fujitsu.com>.

1.3 Changes since the last edition of the manual

This manual contains the following major changes compared to the last edition of the manual:

- The manual has been adjusted for BS2000 V21.0A. It applies to all SE servers.

Changes since BS2000 :

- Magnetic tape cartridge LTO-U8 generation are supported (refer to [Device type table](#) and [Volume type table](#)).

The innovations of BS2000 V21.0A are provided in the relevant sales documents and in the BS2000 OS DX Release Notice under <http://bs2manuals.ts.fujitsu.com>.

1.4 Notational conventions

The following typographical elements are used in this manual:

Output	System output and examples are shown in a typewriter font
	For notes on particularly important information
[]	References to publications are shown in the text by abbreviated titles. The complete title of each document which is referred to by a number is listed in the Related publications section after the corresponding number.

Because the names are referred to so frequently, for the sake of simplicity and clarity the following abbreviations are used:

BS2000 operating system when BS2000 need not be distinguished according to version and configuration.

With standard file names, `<ver>` stands for the internal name of the BS2000 version, e.g. 200 for BS2000 OSD/BC V11.0.

The strings `<date>`, `<time>` and `<version>` in examples specify the current outputs for date, time and version of a software product when the examples are otherwise independent of date, time and version.

2 Initial installation

A new SE server is prepared by the manufacturer so that it is ready for use by the customer. The Server Units are delivered with a pregenerated and preinstalled emergency system. The emergency system is IPL-capable. It is intended for installation and maintenance only and should not be used for everyday operation.

If the emergency system cannot run, it will be created anew by customer support while BS2000 is operating.

If a version changeover of the BS2000 operating system is not possible, you can use the emergency system to perform an initial installation.

The initial installation of the BS2000 V21.0A operating system is prepared and executed by the BS2000 systems support for the required Server Unit.

The DVD drive on the Management Unit (MU) can be used here as an emulated tape device, see note 4 of "[Device type table](#)".

Please refer to the manuals for SE servers.

i The initial installation of BS2000 V21.0A described in this section applies to X2000/M2000 V6.4 and higher.

Conducting the initial installation

The initial installation of BS2000 is almost identical for SU /390 and SU x86. See the following instruction for the necessary installation steps. These steps have to be carried out in the same order as described. Instructions specific to only one type of Server Unit are identified as such.

1. Boot the emergency system (BS2000 V21.0A) using the basic configuration.
 - SU /390: mnemonic: CCF0, device number CCF0
(the emergency system contains a suitable standard IOCF)
 - SU x86: mnemonic D0, device number 0130
2. During the system startup the interactive mode is also started, therefore no further commands are necessary. After the system startup, console and dialog operation are possible via the SE Manager.
3. *Only for SU /390*
 On the basis of your configuration, use the IOGEN utility to generate a customer IOCF (IO configuration file, see "[Rules for generating the I/O configuration data](#)") or (if this has already been done elsewhere) transfer the already generated IOCF to the BS2000 system. The new IOCF has to include the basic configuration of the supplied standard IOCFs with the devices of the MU (consoles, LOCLAN, emulated discs and tapes). This step can be omitted (e.g. after a disk crash) if a valid IOCF still exists on the SU. The SU /390 cannot run without a suitable IOCF.

 The IOCF can be stored on the SVP hard disk using `/WRITE-IOCF`, see the "Commands" manual [2]. The IOCF (the IORSF file) can alternatively also be generated via SE Manager and transferred to the SVP hard disk. A running BS2000 system is not required for this. A more detailed description can be found in chapter "Generating the IO configuration data (IOCF) at the SE Manager" and in the "Operating and Managing" manual [5].
4. *Only for SU /390*
 Shut down the emergency system.
 Perform an IMPL , activate the new IOCF and boot the emergency system .

5. Use the SIR utility routine to create a pubset, see the “Utility Routines” manual [1].
6. Use IMON to install the software (SOLIS deliveries) for the BS2000 operating system and the system-related software on the pubset.

During installation with IMON, all files are installed on the pubset and made ready for activation at the next BS2000 startup).

During installation IMON automatically performs the following actions, among others:

- Provide and activate the message files and the syntax files
 - Provide the necessary REP files
 - Generate the DSSM catalog with SSCM
7. If you are using the BS2000 operating system for the first time, adapt the following files on the pubset to the requirements of your data center:
 - startup parameter file
 - command file (CMDFILE)
 - user catalog entries
 - remote data processing files (SOF file)
 - SJMSFILE
 - ACS catalog
 - GUARDS catalog (if the SECOS software product is used)
 - HSMS/ARCHIVE directories
 - MAREN catalog
 - Parameter files of other software
 8. *Only for SU /390*

If necessary, you can adapt the size of the BS2000 standard EXEC address space (see "[Customizing the BS2000 Control System](#)"). The BS2000 standard EXEC can also be changed in the finalized system.
 9. Terminate the emergency system with shutdown.
 10. Perform a startup of the new system.
 - Perform the IPL of the created pubset.
 - Activate the network configuration with the adapted SOF file for regular dialog operation.
 - Make already existing pubsets available with the commands `/ADD-MASTER-CATALOG-ENTRY` and `/IMPORT-PUBSET`.
 - If necessary, use the SIR utility routine (see the “Utility Routines” manual [1]) to create additional pubsets. Make these pubsets available using `/IMPORT-PUBSET [ACTUAL-JOIN=*FIRST, . . .]`.
 - Set up the required entries in the user catalog in the various pubsets.
 - Make a Backup from the system.
 - Shut down the BS2000 system or continue productive operation.

3 Version changeover

A version changeover refers to the process of installing the BS2000 V21.0 using a previous version BS2000 OSD /BC V10.0 or V11.0 .

If no suitable system with BS2000/OSD-BC V10.0 or higher exists, initial installation is required, see [chapter "Initial installation"](#).

System installation is prepared and carried out by systems support.

During the preparations for a version changeover , productive operation can be continued using the previous version.

Further prerequisites for the version changeover to BS2000 V21.0

- Installation of the BS2000 operating system on a new pubset
- Type D3435 disk storage devices in K or NK2 format are required for the new pubset.
- A suitable IOCF must be installed for the Server Unit /390 (see [chapter "System generation"](#)). Hardware generation with IOGEN or SEM at the MU need only be executed if the I/O configuration is changed.
- No hardware generation is required for the Server Unit x86.

The sequence of steps involved in a version changeover is detailed in the following sections.

Installation preparation (under TSOS)

- Create a new pubset with a paging area for the new BS2000 operating system using the SIR utility
- Install the package BS2OS.MIGRATE V1.0 supplied with SOLIS on the current home pubset, as described in the SOLIS delivery letter
- Save the existing user catalog (using the \$TSOS.SYSSRPM.BACKUP file on the home pubset) with ARCHIVE
- Make the new pubset available:
`/IMPORT-PUBSET ...`
- Read in the SYSSRPM.BACKUP file on the new pubset with ARCHIVE
- Export the new pubset
- Import the new pubset again with
`/IMPORT-PUBSET . . . , RECONSTRUCT-USERCAT=*BY-BACKUP (SCOPE=*ALL)`
- Adjust the user catalog thus created on the new pubset with the PVSREN utility routine (see the "Utility Routines" manual [1]):
`//MODIFY-JOINFILE PUBSET=<new_pubset> ,DEFAULT-CATID=<old_home-pubset> ,NEW-DEFAULT-CATID=<new_pubset>`

Installation of the operating System

The new BS2000 operating System is installed on the new pubset using the IMON utility program. To do this, follow the instructions in the delivery letter from SOLIS for the respective package.

Prepare the new pubset for initial operation

- Create an IPL disk in the new pubset with SIR as decribed in the SOLIS delivery letter (see the "Utility Routines" manual [1]).

- Install further software required for the operation
- Create the customer-specific files on the new pubset (job scheduler, SOF file for BCAM, CMDFILE, startup parameter file, ACS catalog, GUARDS catalog etc. for SECOS, HSMS/ARCHIVE directories, MAREN catalog, etc.)
- For SU /390 you can adapt the size of the BS2000 standard EXEC address space, if necessary. See "Customizing the BS2000 Control System".

Completion of the installation

- Export the new pubset
- Bootstrap the customer system on the new pubset with DIALOG-Startup (not a first start!)
- Load the network components
- Make the required user pubsets known by means of `/ADD-MASTER-CATALOG-ENTRY`
- Save the customer system
- Shut down the customer system / productive operation

4 System generation

The term “system generation” covers all the activities involved in generating and updating a BS2000 operating system.

4.1 System generation on Server Unit x86

The Server Unit x86 requires no system generation.

The peripherals are made known by the configuration in the SE Manager.

The user address space is generated with 2 Gbytes and cannot be modified.

The Fibre Channel Protocol is used as the standard connection technique for tape and disk peripherals.

4.2 System generation on Server Unit /390

Because the I/O configuration data and the BS2000 Control System have been separated, the following objects can be generated:

- a file containing the I/O configuration data (IOCF – I/O Configuration File) with the IOGEN utility routine (hardware generation)
- a BS2000 Control System adjusted to the address space (based on the BS2000 standard EXEC)

Generating the I/O configuration data

Initial installation or a change to the I/O configuration requires (new) generation of the I/O configuration data (hardware generation) with the IOGEN utility routine, see "[Generating the I/O configuration data \(IOCF\) with IOGEN](#)". IOGEN generates the I/O configuration file (IOCF), which defines the entire I/O configuration.

i IOCF files can also be created directly in the SE Manager without running BS2000 and transferred to the SVP.

A hardware generation is not required for a version changeover if the I/O configuration remains unchanged.

Disk controllers and/or disk devices can be exchanged under certain circumstances without requiring a hardware generation, see "[Disk device configuration](#)".

The I/O configuration (channels, controllers, devices) can be modified during operation (dynamic I/O configuration change), see "[I/O configuration](#)".

Customizing the BS2000 Control System

BS2000 Standard EXECs are available on all hardware architectures. A BS2000 control system adjusted to the address space can be generated using the procedure supplied, see the [section "Customizing the BS2000 Control System"](#).

i A customer's own system modules can be defined and loaded as DSSM subsystems.

4.2.1 Generating the I/O configuration data (IOCF) with IOGEN

The IOGEN utility routine generates the file with the I/O configuration data (IOCF) which defines the entire I/O configuration.

Additionally, IOGEN can be used to recover the IOGEN instructions from an IOCF in IORSF format.

4.2.1.1 Starting IOGEN

IOGEN is called with `/START-IOGEN` in dialog mode. The command (domain: UTILITIES) can be entered under any user ID that possesses the STD-PROCESSING privilege.

IOGEN cannot be used from a console.

START-IOGEN	Alias: IOGEN
FUNCTION = *GENERATE-IORSF / *GENERATE-SOURCE	
,INPUT-FILE = *STD / <filename 1..54>	
,SELECT = 0 / <alphanum-name 1..1>	
,VERSION = *STD / <product-version> / <product-version without-corr> / <product-version without-man>	

FUNCTION =

Selection of what is to be generated.

FUNCTION = *GENERATE-IORSF

An IOCF in IORSF format is generated. This is the standard case.

FUNCTION = *GENERATE-SOURCE

IOGEN instructions are recovered from an IOCF in IORSF format. These are stored in a SAM file SYSDAT.IOGEN.<ver>.SRC[.<name>]. <name> is the original generation name of the IOCF, if it exists.

INPUT-FILE =

Specifies the input medium for the IOGEN statements.

INPUT-FILE = *STD

The statements for IOGEN are read from SYSDTA (only possible if FUNCTION = *GENERATE-IORSF).

INPUT-FILE = <filename 1..54>

If FUNCTION = *GENERATE-IORSF: The instructions for IOGEN are read from the specified SAM or ISAM file.

If FUNCTION = *GENERATE-SOURCE: The specified PAM file in IORSF format is read.

SELECT = 0 / <alphanum-name 1..1>

Selects the I/O configuration for generation from the description of a computer network in the input medium, see the [section "An IOGEN description for two or more Server Units"](#).

Permitted values: 0, 1, ..., 9, A, B, ..., F (max. 15 configurations in a network). The default value is 0, i.e. no network function is used.

Ignored if FUNCTION = *GENERATE-SOURCE.

VERSION =

Specifies the version of IOGEN that is to be called.

VERSION = *STD

The highest IOGEN version installed using IMON is started unless a specific version has been selected with IMON.

VERSION = <product-version> / <product-version without-corr> / <product-version without-man>

Specifies the version of IOGEN that is to be called. You can specify the version in different levels of detail. The following specifications are permitted:

nn.nann or n.nann	(e.g. 21.0A00)	full version specification
-------------------	----------------	----------------------------

nn.na or n.na	(e.g. 21.0A)	without correction level
nn.n or n.n	(e.g. 21.0)	without correction level or release version

i n is a digit and a is a letter. You can prefix the specification with the character V or enclose it in quotes.

4.2.1.2 IOGEN statements

The IOGEN statements control the IOGEN run and define the I/O configuration. The statements are read from the input medium which is assigned when IOGEN is started.

The statements for generating the I/O configuration data can be specified in any order before the END statement.

The following statements must/may be specified:

Control IOGEN run	Function
CPGOPT	Define generation options for IOGEN (optional)
END	Terminate IOGEN statements (mandatory)
GEN	Define program name (optional)
IOCFID	Define header text for IOCF (optional)
Describe hardware configuration	Function
CHN	Define channel (mandatory)
CPU	Define CPU (mandatory)
CTL	Define controller (mandatory)
DVC	Define device (mandatory)
General statements	Function
SYSFILE	Change assignment of the input medium (optional)
*	Insert comments (optional)

Please also note [section "Rules for generating the I/O configuration data"](#).

A detailed description of the IOGEN statements is provided in the [section "Statements for IOGEN"](#).

4.2.1.3 IOGEN messages

The IOGEN messages have the message code `NGCnnnn`. You obtain help on individual messages by means of `/HELP-MSG-INFORMATION`.

All messages of IOGEN and of the IOCGEN subroutine are output to `SYSOUT`.

An IOGEN run ends with the message `NGC0A02` (IOCF generated) or with the message `NGC0A44` (IOCF not generated).

4.2.1.4 IOGEN logs

IOGEN generates two logs.

The IOGEN log is written to SYSLST. It contains the following information:

- List of the input statements. All statements that are read in are logged.
- IOCF generation lists
The I/O configuration generated is logged in three tables:
 - The “Physical Channel Listing” contains, for each channel, the generation data and the number of connected controllers and devices.
 - The “Physical Controller Listing” contains, for each controller, the generation data, the number of connected devices and the channel ports with their connection data.
 - The “Physical Device Listing” contains, for each device, the generation data and the controller ports with their connection data.

The IOCGEN log contains detailed information on the I/O units generated.

- The device table contains – sorted according to the CMPG (in order of ascending CMPG numbers) – generation information on all the devices assigned to the CMPG (in order of ascending subchannel numbers).
- Additional information for each controller is output in the controller table.

Output of the IOCGEN log can be controlled using the `PROT` operand of the `CPGOPT` statement, see ["CPGOPT - Define generation options for IOGEN"](#).

4.2.1.5 Generating the IOCF via IOGEN

After the successful IOGEN run, IOGEN generates the IOCF file

`SYSDAT.BS2.<ver>.IOCF[.<name>]` directly with the configuration data of the channel peripherals.

`<name>` is the name which can be specified in the GEN statement.

Internally a further file, `SYSDAT.IOGEN.<ver>.IOCF[.<name>]`, is generated temporarily which contains the data for the IOCFGEN subroutine called.

IOGEN can store its work and result files on K or NK2 pubsets.

After the IOGEN run the generated IOCF file `SYSDAT.BS2.<ver>.IOCF[.<name>]` is saved on the SVP hard disk by the system administrator (TSOS privilege) using `/WRITE-IOCF` and is available for the next system startup.

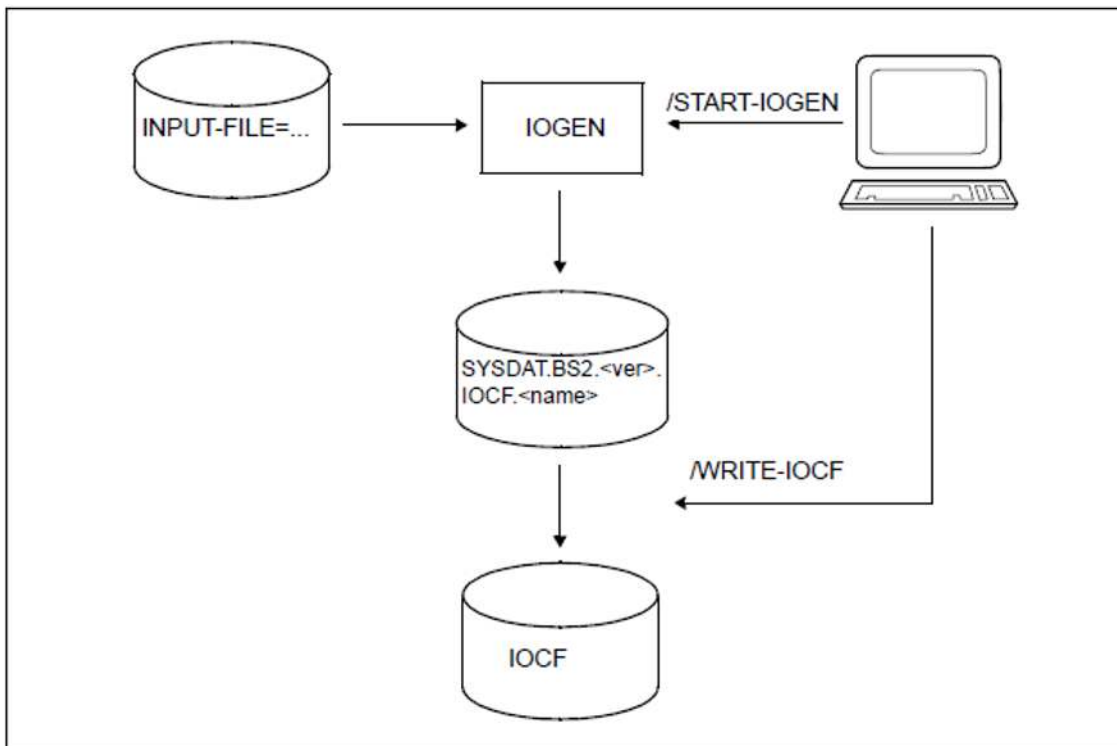

Figure 2: IOCF generation with IOGEN

4.2.2 Generating the I/O configuration data (IOCF) with SE Manager

The I/O configuration data (IOCF or IORSF file respective) can be generated via the SE Manager and transferred to the SVP hard disk. A running BS2000 system is not required for this.

The call at the SE Manager is made via the main page in the menu Devices => <server>(SE </390>) => <unit> (SU</390>) => IORSF-files.

Press "Generate and transfer IORSF file" to start the dialog.

The files containing the IOGEN instructions must first be transferred to the MU on which the SE Manager is running. The transfer takes place in dialog. The IOCF is generated at the MU and can be transferred directly to a selected level of the SVP hard disk of the SU /390. The files created for this purpose on the MU are deleted after the actions are completed. The log file can be copied to the local computer (see below).

Compared to the generation with the utility IOGEN in BS2000 system, the following changes occur:

- The two log files of IOGEN and IOCGEN are combined to one single log file. The operand PROT of the CPGOPT instruction is ignored. The generated log file can be downloaded to the local computer by the dialog when the generation has finished successfully.
- The generated IORSF file is written directly from the MU to the hard disk of the SVP. Downloading is not necessary and is not offered.
- The files with the instructions which have been uploaded from the local computer to the MU are stored there with their file name (but without path name) for generation.
- For file assignments via the IOGEN statement

```
SYSFILE SYSDTA = <fname>
```

<fname> must contain this filename.

- The file names are case sensitive.
- After generation the IOGEN output messages are displayed in a SEM dialog window.
- If the generation was not successful the dialog window shows the IOGEN error messages.

The exact procedure is described in the manual "Operation and Administration" [5] as well as in the online help of the SE Manager.

4.2.3 IOCF terminology

Device number

Each I/O device is identified in the IOCF by a unique device number (0000-FFFF). During generation, this device number (four hexadecimal characters) is derived by IOGEN from the mnemonic (two alphanumeric or four hexadecimal characters) for each device.

The 4-character mnemonic, whose first character may not be zero, is used as the device number.

Mapping of the 2-character mnemonic to the device number (with a leading zero) is performed in accordance with the following algorithm:

1. The mnemonic is converted into a 16-bit string.
2. Bits 2^6 , 2^7 and 2^{14} , 2^{15} are deleted.
3. The 12-bit strings thus created are converted to hexadecimal characters with a leading zero.

Example

Mnemonic	Conversion process	Device number
C'10A1'		X'10A1'
C'M1'	X'D4F1' 1. B' <u>1</u> 101 0100 <u>1</u> 111 0001' <u>eliminate</u> 2. B'0101 0011 0001' 3.	X'0531'

For the exact assignments of mnemonics to device numbers, refer to the allocation table on "[Allocation table: mnemonic name - device number](#)". To simplify matters, we recommend that you assign four-digit mnemonics to disk devices.

In the case of an IPL the device number of the IPL device must be specified.

Subchannel number

The subchannel number refers to an internal numbering system by which all I/O devices are identified. A subchannel represents a device (DVC).

Subchannel numbers are assigned by IOGEN without a gap, starting at zero.

Control unit number

The control unit number represents a hardware controller. It is 16 bits long and, like the device number, is derived from the controller's mnemonic.

Channel Control Unit Connection (CCUC)

The Channel Control Unit Connection (CCUC) represents a connection between controller and channel. A CCUC entry is created for each of these connections in the IOCF.

Communication Path Group (CMPG)

A Communication Path Group (CMPG) is a system-internal structure which comprises up to eight CCUCs. The CMPG numbers are assigned by IOGEN without a gap starting with zero.

Each device is assigned to precisely one CMPG. This CMPG must contain all controller channel ports for this device.

A CCUC may reside in only one CMPG. Here all controllers which are linked by jointly used devices are included in a CPMG with their channel ports.

A CMPG is thus the logical representation of the following controller types:

- A controller whose connected devices have no further controller ports on this server.
- Two to eight controllers which are interconnected by jointly used devices.

However, no more than eight CCUCs may be defined in a CMPG.

4.2.4 Fibre Channel

Fibre Channel (FC, fiber optic technology) is a method for setting up high-performance connections between servers and their periphery. This architecture uses the bit-serial transmission method for data over fibre optic cables. This enables large quantities of data to be transported at high speed over long distances.

The Fibre Channel Protocol is supported on Server Unit /390 by BS2000 via channel type IBF (MODE=FCP).

BS2000 supports connections of the type "fabric" for the storage systems attached with the Fibre Channel Protocol. Here dedicated connections are set up between Server Units and storage systems. A Server Unit sees only the storage systems assigned to it. The Server Units and storage systems form domains which are assigned to each other via switches (called "zoning").

Information about the devices supported is provided in the Release Notice on BS2000 OSD/BC.

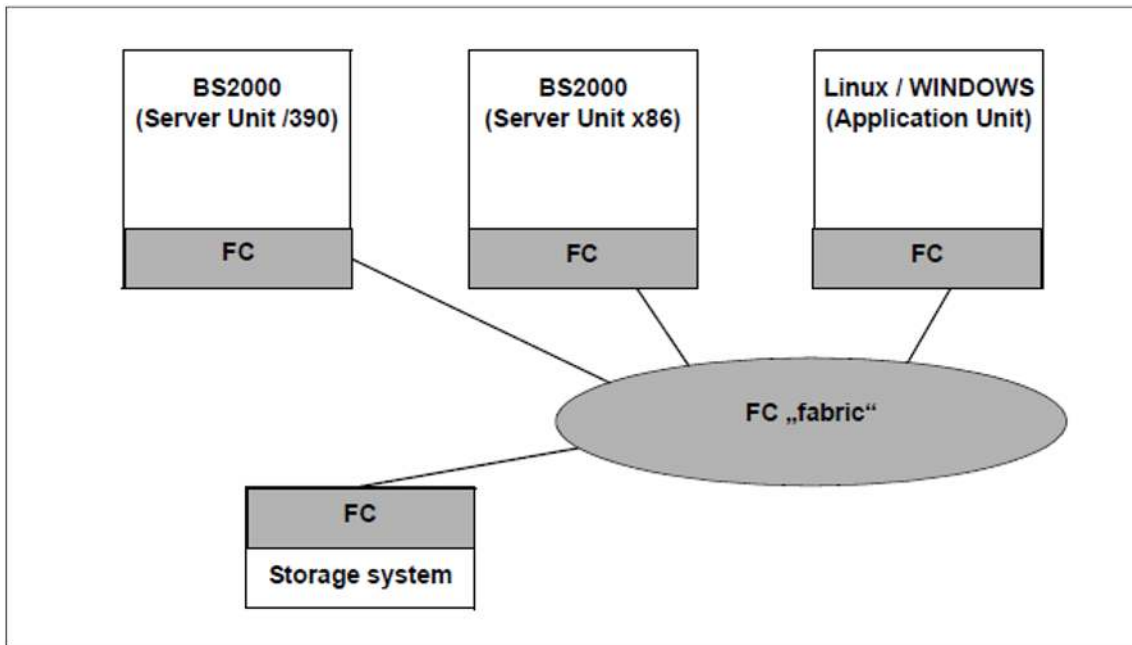

Figure 3: Integration of the Server Units of an SE server into a heterogeneous SAN

4.2.5 Rules for generating the I/O configuration data

Information about the various hardware components, interfaces and maximum values for the SE servers is available online: <https://www.fujitsu.com/emeia/products/> > *Fujitsu Servers* > *BS2000 Mainframes* > *Fujitsu Server BS2000* > *“Model selection”*.

- i IOGEN checks that the IOCF capacity limits are not exceeded.
IOGEN does not check whether the maximum number of channels has been exceeded.

4.2.5.1 I/O configuration

The I/O configuration of a Server Unit is defined by the statements for

- CPU (CPU statement)
- Channel (CHN statement)
- Controller (CTL statement)
- Device (DVC statement)

In [figure 4](#) you are shown the structure of the I/O configuration for a Server Unit:

Hardware units supported

CPUs

The CPUs of Server Unit /390.

Channels

Channel type IBF (MODE=FCP) is supported, see [section "Fibre Channel"](#). When the channel type is generated, 02-FF must be specified as the channel path identifier in the MODE operand of the CHN statement.

FCLINK channel 00 is required for hardware tests, see [section "Configuration for the hardware test"](#)

Controllers

Controllers are regarded as connections between channels and devices.

Devices

See [section "Device type table"](#).

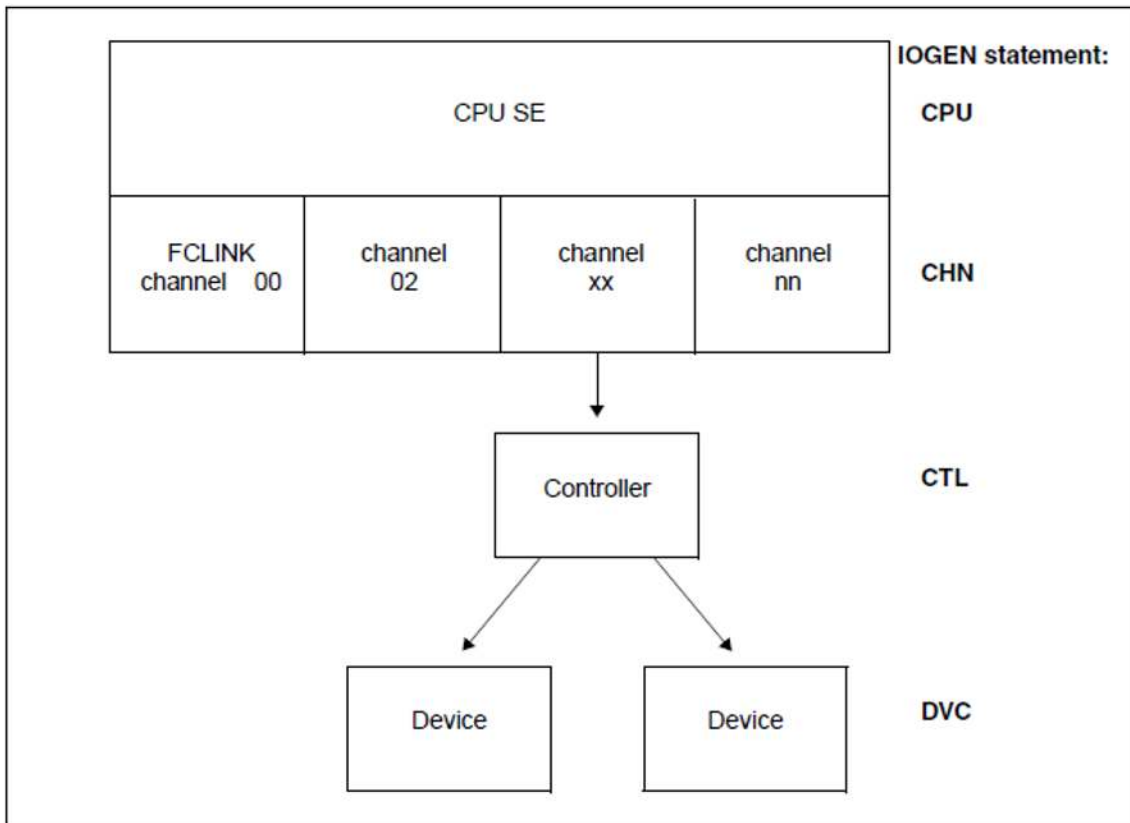

Figure 4: Structure of the configuration for a Server Unit

Dynamic modification of the I/O configuration

The I/O configuration of the Server Unit can be modified dynamically while BS2000 is operating. Channels, controllers and devices can be included in the I/O configuration or removed from it.

New units which are to be included must be defined in the IOCF. Space for up to 512 additional components (channel, controller, device, CCUC, CMPG) is provided in the IOCF. If it can be foreseen that more than 512 components will be added, these should be generated in advance. Your entries in the IOCF can then be modified later in accordance with the actual configuration.

The channels on boards which were present upon IMPL and are not yet used must also be generated in advance (without connected devices and controllers). It is otherwise not possible to place these channels in service dynamically.

Detailed information on dynamic modification of the I/O configuration is provided in the relevant sections of the manual "Introduction to System Administration" [4].

Disk controllers and devices can be replaced dynamically while BS2000 is operating, see the section ["Disk device configuration"](#).

4.2.5.2 Configuration for the hardware test

FCLINK channel 00 is required for hardware tests ("HST", customer support) of Server Unit /390. A controller with CUADD=3F and without devices must be generated on this Server Unit.

FCLINK channel 00 is reserved for hardware tests.

Example (extract from the generation example on "[Generation example \(IOGEN statements\)](#)")

```
CHN 00,IBF,MODE=CNC  
CTL HS,BLM,(00,0),CUADD=3F
```

4.2.5.3 Configuration of the Management Unit (MU)

The Management Unit (MU) is generated as a controller on its own channel. The mnemonic is freely selectable.

If there is a second, redundant MU, this is also generated on its own channel. This channel may not be the channel of the first MU.

It is also possible to create multiple logical controllers on the same channel for one MU. Thus, the different device types on one MU can be generated on individual logical controllers. This is especially recommended if you plan to generate emulated disk devices, because it avoids conflicts during the time monitoring of the channel system.

Configuration of console devices connected to the MU

A console distribution program (KVP) on the MU implements and controls the BS2000 consoles. Two KVP and console devices are emulated for BS2000. Further information on this is provided in the “Operation and Administration” manual [5].

The following must be observed when generation takes place:

- Console devices are generated on the MU as devices with the device type code 64.
- Console devices are generated with two addresses (LUNs); the second address must be 1 higher than the first address.
In BS2000 the mnemonics C2/C3 with LUNs 00C3/00C4 are used as the IPL console devices in the first MU. If there is a second, redundant MU, by default the mnemonics C4/C5 with LUNs 00C3/00C4 are used as the IPL console devices in the second MU.
The mnemonics can also be freely selected. They must then be set for the IPL using the SE Manager on the SVP.
- When generating console devices for VM2000 guest systems, the mnemonics must also be selected in such a way that the device numbers derived from them for each device pair must follow directly one after the other. This condition is not checked by IOGEN.
- If virtual consoles are to be supported in VM2000, these must be generated with device type code 02 or 03, see the “VM2000” manual [13].
- The IPL console is recognized automatically by BS2000. The other consoles must also be made known to the system via the parameter service (parameter record OPR, DEFINE-CONSOLE), see the “Introduction to System Administration” [4].
- The number of virtual consoles (VM2000) and KVP consoles (which are defined or automatically recognized using the parameter service) may not exceed 24. IOGEN checks only whether the number of virtual consoles is no higher than 24.
- The total number of all generated devices with device type code 64 and other console devices may not exceed 224. This condition is not checked by IOGEN.

Configuration of LOCLAN devices connected to the MU

Connections between the MU and BS2000 using TCP/IP can be employed via LOCLAN. Under VM2000 this connection also permits a LAN connection between the guest systems. Two LOCLAN devices must be configured for a LOCLAN connection.

LOCLAN devices are generated on the MU as devices with the device type code 6D.

On the first MU, LOCLAN devices are preconfigured with the mnemonics CC80/CC81 and LUNs 0080/0081.

When there is a second, redundant MU, the LOCLAN devices are preconfigured there with the mnemonics CD80 /CD81 and LUNs 0080/0081.

Configuration of emulated tape devices connected to the MU

The CD/DVD drive of the MU is operated as an emulated tape device in BS2000.

An emulated tape device is also possible on the MU on the basis of a file (EMFILE).

Emulated tape devices are generated on the MU as devices with the device type code E8.

A CD-ROM drive with the mnemonic T0 (LUN 0060) and an EMFILE with the mnemonic T1 (LUN 0061) are preconfigured on the first MU.

When there is a second, redundant MU, a CD-ROM drive is preconfigured there with the mnemonic TA (LUN 0060) and an EMFILE with the mnemonic TB (LUN 0061).

Configuration of emulated disk devices connected to the MU

Up to two disks of the type EMDISK are emulated on the MU.

Emulated disk devices are generated on the MU as devices with the device type code A5.

On the first MU, the mnemonics CCF0 (LUN 0030) and CCF1 (LUN 0031) are designated for this task.

If there is a second, redundant MU, then the mnemonics CDF0 (LUN 0030) and CDF1 (LUN 0031) are designated for this task on that MU.

To avoid conflicts during the monitoring of the channel system, a separate logical controller should be defined for the emulated disk devices.

Example with redundant MU and emulated disk devices on a separate controller

(see the generation example on "[Generation example \(IOGEN statements\)](#)")

```

CHN 40,IBF,MODE=FCP                * CHN CONNECTED TO MU-1
CHN 09,IBF,MODE=FCP                * CHN CONNECTED TO MU-2
*
*****
*   MU-1 AT FCP CHN 40                *
*****
CTL CC80,BLM,(40,0,00000000000000) * MU-1 (DIRECT CONNECTION)
*****
*   KVP MAIN CONSOLE MONITOR SYSTEM  *
*****
DVC C2,64,A,C3,(CC80)
DVC C3,64,A,C4,(CC80)
*****
*   KVP MAIN CONSOLE VM2000 GUEST SYSTEMS  *
*****
DVC C6,64,D,A0,(CC80),MULT=4        * KVP VM2-VM3
DVC CA,64,D,A4,(CC80),MULT=8        * KVP VM4-VM7
DVC CJ,64,D,AC,(CC80),MULT=8        * KVP VM8-VMB
DVC CS,64,D,B4,(CC80),MULT=8        * KVP VMC-VMF
*****
*   MT EMULATIONS                    *
*****
DVC T0,E8,D,60,(CC80)               * CDROM
DVC T1,E8,D,61,(CC80),MULT=6        * FILE EMULATION
DVC T7,E8,D,FF,(CC80)               * FILE EMULATION FW DUMP
*****
*   LOCLAN EMULATION ($DIALOG)        *
*****
DVC CC80,6D,A,80,(CC80),MULT=32
*****
*   DISK EMULATION MU-1                *
*****
CTL CC83,BLM,A,(40,0,00000000000000) * DIRECT CONNECTION DISK
DVC CCF0,A5,D,0030,(CC83,I),MULT=2
*****
*   MU-2 AT FCP CHN 09                *
*****
CTL CD80,BLM,(09,0,0000000000000000) * MU-2 (DIRECT CONNECTION)
*****
*   KVP CONSOLE MONITOR SYSTEM        *
*****
DVC C4,64,A,C3,(CD80)
DVC C5,64,A,C4,(CD80)
*****
*   KVP CONSOLE VM2000 GUEST SYSTEMS  *
*****
DVC D6,64,D,A0,(CD80),MULT=4        * KVP VM2-VM3
DVC DA,64,D,A4,(CD80),MULT=8        * KVP VM4-VM7
DVC DJ,64,D,AC,(CD80),MULT=8        * KVP VM8-VMB
DVC DS,64,D,B4,(CD80),MULT=8        * KVP VMC-VMF
*****
*   MT EMULATIONS                    *

```

```
*****
DVC TA,E8,D,60,(CD80) * CDROM
DVC TB,E8,D,61,(CD80),MULT=6 * FILE EMULATION
DVC TH,E8,D,FF,(CD80) * FILE EMULATION FW DUMP
*****
* LOCLAN EMULATION ($DIALOG) *
*****
DVC CD80,6D,A,80,(CD80),MULT=32
*****
* DISK EMULATION MU-2 *
*****
CTL CD83,BLM,A,(09,0,0000000000000000) * DIRECT CONNECTION DISK
DVC CDF0,A5,D,0030,(CD83,I),MULT=2
```

4.2.5.4 Network configuration

Only the LAN devices connected to the HNC must be configured.

LAN devices are generated on the HNC as devices with the device type code 6D.

The LAN connection is generated in BCAM, see the “BCAM” manual [11].

The BS2000 devices for the control LAN (MCNPR, see the “Operation and Administration” manual [5]) are also connected to the HNC.

By default the device pairs for the control LAN are configured with the LUNs 0040/0041 (MN CC40/CC41) through 005E/005F (MN CC5E/CC5F) on the HNC.

For the redundant control LAN, the device pairs are configured with the LUNs 0040/0041 (MN CD40/CD41) through 005E/005F (MN CD5E/CD5F).

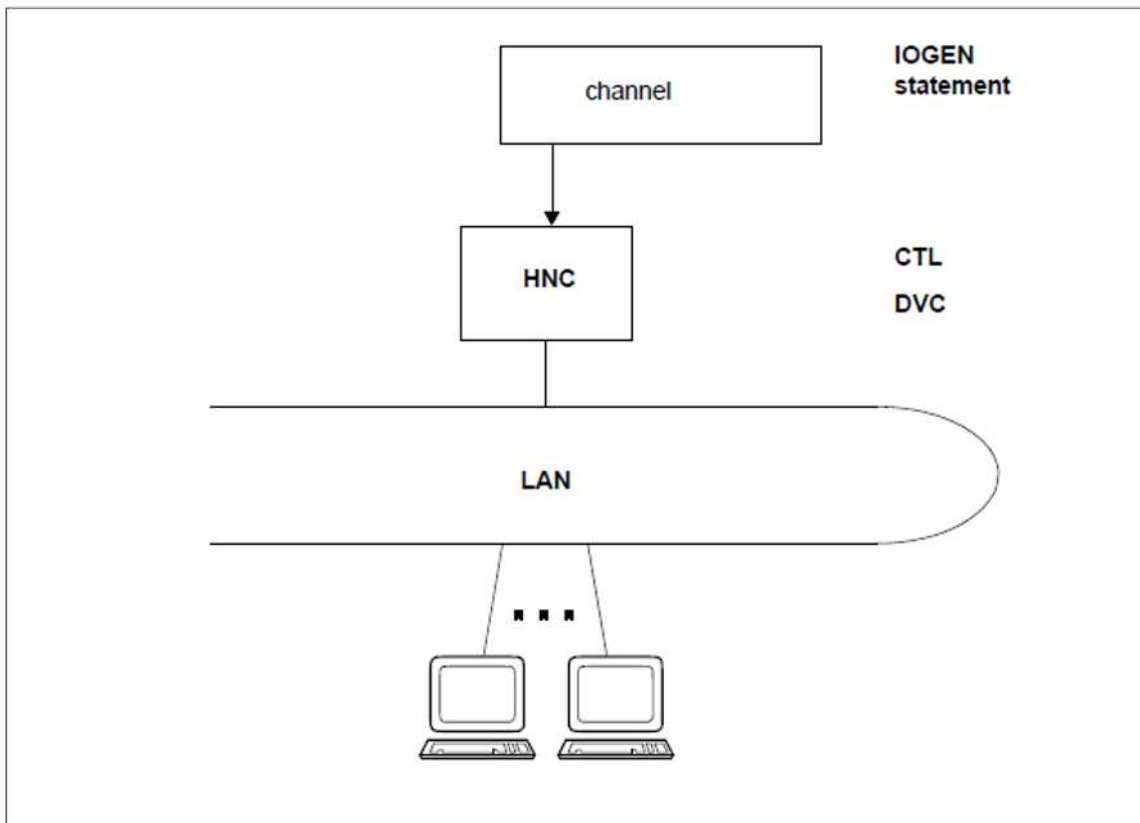

Figure 5: Structure of a LAN configuration

Example with two HNCs (see the "Generation example (IOGEN statements)")

```
CHN 08,IBF,MODE=FCP                * CHN CONNECTED TO HNC-1
CHN 41,IBF,MODE=FCP                * CHN CONNECTED TO HNC-2
*
*****
*   HNC-1 AT FCP CHN 08                *
*****
CTL CC00,BLM,(08,0,0000000000000000) * HNC-1 (DIRECT CONNECTION)
*****
*   DATA LAN                          *
*****
DVC CC00,6D,A,0000,(CC00),MULT=64
*****
*   CONTROL LAN                        *
*****
DVC CC40,6D,A,0040,(CC00),MULT=32
*****
*   HNC-2 AT FCP CHN 41                *
*****
CTL CD00,BLM,(41,0,0000000000000000) * HNC-2 (DIRECT CONNECTION)
*****
*   DATA LAN                          *
*****
DVC CD00,6D,A,0000,(CD00),MULT=64
*****
*   CONTROL LAN                        *
*****
DVC CD40,6D,A,0040,(CD00),MULT=32
```

4.2.5.5 Disk device configuration

Disk devices are generated as devices with the device type code A5 or AA on a disk controller.

When you attach a disk device, the attributes of the device are ascertained dynamically and used to update the BS2000 device tables regardless of the generated device type code (within the device type codes for disk devices).

The device and controller ports and the operating mode of the controllers are defined during generation with IOGEN and entered in the IOCF.

For information on “dynamic I/O configuration modification”, see ["I/O configuration"](#).

Parallel Access Volume (PAV)

The generation of Parallel Access Volumes (PAV) is recommended for ETERNUS DX/AF disk storage systems, see "PAV" in section ["General conditions for hardware generation"](#) and in the “Introduction to System Administration” [4] manual.

For Fast DPAV Alias devices the device type code A6 is used.

Changing disk controllers and/or devices

Replacing a previously generated (i.e. old) storage system by a new one results in changed WWPNs of the Storage Ports. Therefore the CTL statements have to be adapted to the new FC target ports. An updated generation and IOCF is required. No further changes are required if the following conditions apply:

- the same server channel ports are used
- the devices connected to the new disk controller have the same addresses (LUNs) as the devices connected to the old disk controller

Generating virtual devices (SNAP disks)

In BS2000 for SU /390, virtual devices or SNAP disks must be generated as disks of the same type as the original disks. When a pubset with snapsets is to be used on more than one BS2000 system, the same number of SNAP disks must be generated on all of these systems.

For information on generating virtual devices on SU x86, see the “SHC-OSD” manual [12].

4.2.5.6 Creating device addresses

The device address determines the access path to a device. A device can have up to eight access paths/device addresses on a Server Unit.

The device addresses must be unique within the configuration.

The device address consists of

- the channel path identifier,
- the 8-byte World-Wide Port Number of the port to which the controller is connected (`wwpn` operand of the CTL statement),
- the 2-byte Logical Unit Number via which the device is reached by the controller (`lun` operand of the DVC statement) and

Restrictions

1. A maximum of 256 devices (including the PAV alias devices) may be connected to a logical controller; their Logical Unit Numbers must be identical in the high-order byte. The alias addresses must differ from each other and from the low-order byte of all Logical Unit Numbers of the devices on this controller.
2. If multiple logical controllers are connected to the same port, i.e. with the same World-Wide Port Number, all the devices connected to these controllers must have different Logical Unit Numbers (exception: XPAV, see the "Introduction to System Administration") [4].
This can be achieved by devices connected to different logical controllers with the same World-Wide Port Number having a different high-order byte in their Logical Unit Number.
It is, however, also possible to distribute devices whose Logical Unit Numbers are identical in the high-order byte over several logical controllers with the same World-Wide Port Number. They must then differ in the low-order byte of the Logical Unit Number.
3. In the case of a direct connection (`WWPN='0000000000000000'`), up to 256 devices can be generated on the channel.
4. Different access paths/device addresses for the same device must differ in the channel path identifier.

Generating a controller with more than 256 devices on one port

The hardware controller is divided into multiple logical controllers each with a maximum of 256 devices. The Logical Unit Numbers of the devices connected to it differ in their high-order byte. The first logical controller thus has ports 0000 - 00FF, the second logical controller ports 0100 - 01FF, and so on. This satisfies the first and second restrictions.

All logical controllers are reached via the same World-Wide Port Number.

Example of generating a controller with 2048 devices and 4 ports

The IOGEN statements are, for example:

```
*
* 4 channels (F0 through F3)
*
CHN F0,IBF,MODE=FCP
CHN F1,IBF,MODE=FCP
CHN F2,IBF,MODE=FCP
CHN F3,IBF,MODE=FCP
*
* 8 logical controllers (C0 through C7) each with 4 channel ports
* via 4 ports with World-Wide Port Numbers (wwpn1 through wwpn4);
* 256 devices per logical controller
*
CTL C0,,(F0,0,wwpn1),(F1,0,wwpn2),(F2,0,wwpn3),(F3,0,wwpn4)
DVC F000,A5,D,0000,(C0),MULT=256          * Devices F000 ... F0FF *
*
CTL C1,,(F0,0,wwpn1),(F1,0,wwpn2),(F2,0,wwpn3),(F3,0,wwpn4)
DVC F100,A5,D,0100,(C1),MULT=256          * Devices F100 ... F1FF *
*
CTL C2,,(F0,0,wwpn1),(F1,0,wwpn2),(F2,0,wwpn3),(F3,0,wwpn4)
DVC F200,A5,D,0200,(C2),MULT=256          * Devices F200 ... F2FF *
*
CTL C3,,(F0,0,wwpn1),(F1,0,wwpn2),(F2,0,wwpn3),(F3,0,wwpn4)
DVC F300,A5,D,0300,(C3),MULT=256          * Devices F300 ... F3FF *
*
CTL C4,,(F0,0,wwpn1),(F1,0,wwpn2),(F2,0,wwpn3),(F3,0,wwpn4)
DVC F400,A5,D,0400,(C4),MULT=256          * Devices F400 ... F4FF *
*
CTL C5,,(F0,0,wwpn1),(F1,0,wwpn2),(F2,0,wwpn3),(F3,0,wwpn4)
DVC F500,A5,D,0500,(C5),MULT=256          * Devices F500 ... F5FF *
*
CTL C6,,(F0,0,wwpn1),(F1,0,wwpn2),(F2,0,wwpn3),(F3,0,wwpn4)
DVC F600,A5,D,0600,(C6),MULT=256          * Devices F600 ... F6FF *
*
CTL C7,,(F0,0,wwpn1),(F1,0,wwpn2),(F2,0,wwpn3),(F3,0,wwpn4)
DVC F700,A5,D,0700,(C7),MULT=256          * Devices F700 ... F7FF *
```

4.2.5.7 General conditions for hardware generation

Mnemonic names (mnemonics, MNs)

Mnemonic names must be unique within a given configuration level (controllers, devices).

Two-character alphanumeric or four-character hexadecimal mnemonic names designate devices and controllers. Channels are generated with their channel path identifier.

For each controller, a two-character alphanumeric or four-character hexadecimal mnemonic name can be chosen.

A two-character alphanumeric mnemonic name can always be selected for devices. A four-character hexadecimal device mnemonic (1000 - FFFF) is permitted for all disk and tape devices as well as for network and LOCLAN devices.

Channel or controller without device connection

The channels on boards which were present upon IMPL and are not yet used must also be generated in advance (without connected devices and controllers). It is otherwise not possible to place these channels in service dynamically, see the section "[Dynamic modification of the I/O configuration](#)".

Channels can therefore also be generated without the controllers connected to them.

Generation is aborted when a hardware unit is defined for which no device connection has been defined. Exception: the controller for the hardware test, see "[Configuration for the hardware test](#)".

Configuration statuses of the hardware units

Neither detached indicators for channel and controller nor removed indicators for controller and device have any effect (they can still be specified for compatibility reasons).

Channels and controllers are generated as "attached". The Configuration status of a device is specified in the DVC statement.

Paths between channels, controllers and devices are generated as "included".

The generated Configuration statuses can be modified during system initialization via the startup parameter service (IOCONF parameter record) or while BS2000 is operating using the reconfiguration commands.

The plausibility of the configuration defined and possibly modified using the startup parameter service is checked in the course of system initialization. The rules applied to test this are based in the hardware of the system.

In the course of system initialization, the hardware configuration is checked and made consistent from the channel level to the device level in accordance with the following rules:

- A path is marked as removed (r) if the superordinate hardware unit is detached (d).
- A hardware unit is marked as detached (d) when all paths to superordinate hardware units are removed (r).

Example

A device is attached to only one controller, and this controller is detached. The path from this device to the controller is marked as "removed" (r) and the device itself is marked as "detached" (d).

i At generation time, the following rules should be observed during system initialization:

- BS2000 consoles from which the system is to be started must be attached and
- the path to the devices for the home pubset and the paging disks must be included. The device may be detached, it will be attached automatically during system initialization.

Parallel Access Volume (PAV)

Parallel Access Volume (PAV) should be used for ETERNUS disk storage systems, see the “Introduction to System Administration” [4].

IOGEN is used during hardware generation or the `/ADD-IO-UNIT` command is used during ongoing operation to generate one base device and one or more alias devices for a PAV with the following properties and restrictions:

- The base device and alias device(s) represent the same volume in the disk storage system
- For the alias devices the low-order byte of the LUN must differ from the alias address (see the `pav-addr` operand of the DVC statement, “[DVC - Define device](#)”)
- An alias device must have a higher device number than the associated base device

Standard PAV

A standard PAV is characterized by the following properties:

- The base device and alias device(s) are generated on the same controller (see the CTL statement, “[CTL - Define controller](#)”)
- The base device and alias device(s) have an identical LUN

Extended PAV (XPAV)

For the base controller with the base devices for the real volumes, an alias controller is supported with alias devices and the following properties:

- Only alias devices are connected to the alias controller
- XPAV variant 1
 - The base controller and alias controller are generated on the same controller port
 - The base device and alias device(s) have an identical LUN
- XPAV variant 2
 - The base controller and alias controller are generated on different controller ports
 - The base device and alias device(s) can also have different LUNs, but the low-order bytes of the LUNs must be identical

FastDPAV

The “FastDPAV” function, an optimized DPAV, is offered for Server Units SU /390 that support a modification of the LUN for alias devices when starting an I/O.

With FastDPAV, a pool of FastDPAV aliases is generated for a set of logical volumes with identical channel paths (channel-to-port connection to the disk storage system) without a fixed association with one of these logical volumes. For a FastDPAV alias device, the LUN is only specified or modified when an I/O is started.

FastDPAV aliases are generated as follows:

- Device name: A FastDPAV alias device must have a larger device number than a potentially associated FastDPAV base device.
- Device code: A6
- Configuration state: A or D, not relevant
- LUN: FF00 to FFFF
- Controllers: FastDPAV aliases are generated on their own controllers.
- FastDPAV alias devices must have the same logical control ports as the associated FastDPAV base devices. This means:

If the base devices have **n** logical controllers with the lexically ordered mnemonics $\langle b_ctl_1 \rangle$ to $\langle b_ctl_n \rangle$ and each logical controller $\langle b_ctl_i \rangle$ has the channel paths $\langle cpid_{i1}, wwpn_{i1} \rangle$ to $\langle cpid_{ik}, wwpn_{ik} \rangle$, then the alias devices must also have **n** logical controllers with the lexically ordered mnemonics $\langle a_ctl_1 \rangle$ to $\langle a_ctl_n \rangle$ and each logical controller $\langle a_ctl_i \rangle$ has the channel connectors $\langle cpid_{i1}, wwpn_{i1} \rangle$ to $\langle cpid_{ik}, wwpn_{ik} \rangle$.

i Lexical ordered means: A-Z before 0-9.

4.2.6 Generation example (IOGEN statements)

```

GEN IOCONF,NAME=SU710
CPGOPT PROT=*FILE
CPU SE
IOCFID 'SU710'
*****
*   FCLINK CHN FOR HST                                     *
*****
CHN 00,IBF,MODE=CNC                                     *   HARDWARE TEST CHN
*****
*   DIRECT FCP CHN                                       *
*****
CHN 08,IBF,MODE=FCP                                     *   CHN CONNECTED TO HNC-1
CHN 09,IBF,MODE=FCP                                     *   CHN CONNECTED TO MU-2
CHN 40,IBF,MODE=FCP                                     *   CHN CONNECTED TO MU-1
CHN 41,IBF,MODE=FCP                                     *   CHN CONNECTED TO HNC-2
*****
*   FCP CHN FABRIC1                                       *
*****
CHN 0A,IBF,MODE=FCP                                     *   DISK
CHN 0B,IBF,MODE=FCP                                     *   TAPE
CHN 0C,IBF,MODE=FCP                                     *   DISK
*****
*   FCP CHN FABRIC2                                       *
*****
CHN 0D,IBF,MODE=FCP                                     *   DISK
CHN 0F,IBF,MODE=FCP                                     *   DISK
*****
*   CONTROL UNIT HST                                       *
*****
CTL HS,BLM,(00,0),CUADD=3F                             *   HARDWARE TEST
*****
*   MU-1 AT FCP CHN 40                                     *
*****
CTL CC80,BLM,(40,0,0000000000000000)                 *   MU-1 (DIRECT CONNECTION)
*****
*   KVP MAIN CONSOLE MONITOR SYSTEM                       *
*****
DVC C2,64,A,C3,(CC80)
DVC C3,64,A,C4,(CC80)

*****
*   KVP MAIN CONSOLE VM2000 GUEST SYSTEMS                 *
*****
DVC C6,64,D,A0,(CC80),MULT=4                          *   KVP VM2-VM3
DVC CA,64,D,A4,(CC80),MULT=8                          *   KVP VM4-VM7
DVC CJ,64,D,AC,(CC80),MULT=8                          *   KVP VM8-VMB
DVC CS,64,D,B4,(CC80),MULT=8                          *   KVP VMC-VMF
*****
*   MT EMULATIONS                                         *
*****
DVC T0,E8,D,60,(CC80)                                  *   CDROM
DVC T1,E8,D,61,(CC80),MULT=6                          *   FILE EMULATION
DVC T7,E8,D,FF,(CC80)                                  *   FILE EMULATION FW DUMP
*****
*   LOCLAN EMULATION ($DIALOG)                           *
*****

```

```

DVC CC80,6D,A,80,(CC80),MULT=32
*****
*   DISK EMULATION MU-2                                     *
*****
CTL CD83,BLM,A,(09,0,0000000000000000) * DIRECT CONNECTION DISK
DVC CDF0,A5,D,0030,(CD83,I),MULT=2
*****
*   MU-2 AT FCP CHN 09                                     *
*****
CTL CD80,BLM,(09,0,0000000000000000) * MU-2 (DIRECT CONNECTION)
*****
*   KVP CONSOLE MONITOR SYSTEM                             *
*****
DVC C4,64,A,C3,(CD80)
DVC C5,64,A,C4,(CD80)
*****
*   KVP CONSOLE VM2000 GUEST SYSTEMS                       *
*****
DVC D6,64,D,A0,(CD80),MULT=4           * KVP VM2-VM3
DVC DA,64,D,A4,(CD80),MULT=8           * KVP VM4-VM7
DVC DJ,64,D,AC,(CD80),MULT=8           * KVP VM8-VMB
DVC DS,64,D,B4,(CD80),MULT=8           * KVP VMC-VMF
*****
*   MT EMULATIONS                                         *
*****
DVC TA,E8,D,60,(CD80)                   * CDROM
DVC TB,E8,D,61,(CD80),MULT=6            * FILE EMULATION
DVC TH,E8,D,FF,(CD80)                   * FILE EMULATION FW DUMP
*****
*   LOCLAN EMULATION ($DIALOG)                           *
*****
DVC CD80,6D,A,80,(CD80),MULT=32
*****
*   HNC-1 AT FCP CHN 08                                     *
*****
CTL CC00,BLM,(08,0,0000000000000000) * HNC-1 (DIRECT CONNECTION)
*****
*   DATA LAN                                             *
*****
DVC CC00,6D,A,0000,(CC00),MULT=64
*****
*   CONTROL LAN                                           *
*****
DVC CC40,6D,A,0040,(CC00),MULT=32
*****
*   HNC-2 AT FCP CHN 41                                     *
*****
CTL CD00,BLM,(41,0,0000000000000000) * HNC-2 (DIRECT CONNECTION)
*****
*   DATA LAN                                             *
*****
DVC CD00,6D,A,0000,(CD00),MULT=64
*****
*   CONTROL LAN                                           *
*****
DVC CD40,6D,A,0040,(CD00),MULT=32
*****
*   ETERNUS DX #1                                         *
*****

```

```
CTL 3400,BLM,(0A,0,500000E0D4301C80),(0C,0,500000E0D4301C92)
CTL 3401,BLM,(0D,0,500000E0D4301CA1),(0F,0,500000E0D4301CB3)
DVC 3400,A5,D,0000,(3400),(3401),MULT=256
*****
*   ETERNUS DX #2                                           *
*****
CTL FC00,BLM,(0C,0,500000E0D4006690)
CTL FC01,BLM,(0F,0,500000E0D4006680)
DVC FC0A,AA,D,000A,(FC00),(FC01),MULT=25
*****
*   TAPES AT CHN 0B, FABRIC1                               *
*****
*   ETERNUS CS                                           *
CTL L0,BLM,(0B,0,10000000C94CBC42)
DVC AB00,CE,D,0000,(L0),MULT=8
DVC AB08,C4,D,0008,(L0),MULT=120
END
```

4.2.7 Generation example for FastDPAV

The following IOGEN statements generate 1024 PAV volumes with LUNs 0000 through 03FF on 4 channel paths.

The realization takes place with 1024 FastDPAV basic devices as well as 128 FastDPAV alias devices. For a PAV volume, exactly one FastDPAV base device and one (or more) FastDPAV alias device (s) can be used for the I/O execution. For the duration of the I/O execution, a FastDPAV alias device is assigned the LUN of the assigned PAV volume, ie a LUN between 0000 and 03FF.

```
*****
* 256 FastDPAV base devices 8000 to 80FF , LUNs 0000 to 00FF *
*****
CTL 8000,BLM,(0A,0,5000097208132110),(0D,0,5000097208132124)
CTL 8001,BLM,(4A,0,500009720813211C),(4B,0,5000097208132114)
DVC 8000,A5,D,0000,(8000),(8001),MULT=256
*****
* 256 FastDPAV base devices 8100 to 81FF , LUNs 0100 to 01FF *
*****
CTL 8100,BLM,(0A,0,5000097208132110),(0D,0,5000097208132124)
CTL 8101,BLM,(4A,0,500009720813211C),(4B,0,5000097208132114)
DVC 8100,A5,D,0100,(8100),(8101),MULT=256
*****
* 256 FastDPAV base devices 8200 to 82FF , LUNs 0200 to 02FF *
*****
CTL 8200,BLM,(0A,0,5000097208132110),(0D,0,5000097208132124)
CTL 8201,BLM,(4A,0,500009720813211C),(4B,0,5000097208132114)
DVC 8200,A5,D,0200,(8200),(8201),MULT=256
*****
* 256 FastDPAV base devices 8300 to 83FF , LUNs 0300 to 03FF *
*****
CTL 8300,BLM,(0A,0,5000097208132110),(0D,0,5000097208132124)
CTL 8301,BLM,(4A,0,500009720813211C),(4B,0,5000097208132114)
DVC 8300,A5,D,0300,(8300),(8301),MULT=256
*****
* 128 FastDPAV base devices 8F00 to 8F7F , LUNs FF00 to FF7F *
*****
CTL 8F00,BLM,(0A,0,5000097208132110),(0D,0,5000097208132124)
CTL 8F01,BLM,(4A,0,500009720813211C),(4B,0,5000097208132114)
DVC 8F00,A6,D,FF00,(8F00),(8F01),PAV=01,MULT=128
```

4.2.8 An IOGEN description for two or more Server Units

The hardware configuration for two or more Server Units /390 can be defined in a shared IOGEN description. This description then provides the input for generating each individual Server Unit.

The hardware units which occur only once physically (e.g. devices, controllers) should only be described once. The physically available channels comprise the channels from all Server Units in the network.

The operand `SELECT=n` ($n = 1, \dots, 9, A, \dots, F$) in `/START-IOGEN` specifies the Server Unit for which the description is to be used as the basis for generation.

If the `SELECT` operand is not specified or if `SELECT=0` is specified, then the description may only contain one Server Unit.

If `SELECT=n` ($n > 0$) applies, the n th `GEN` statement and the `CPU` and `IOCFID` statements following it are evaluated. A different sequence of `GEN`, `CPU`, `IOCFID` statements (for generating a different Server Unit) is ignored.

Channel path identifiers are assigned to the Server Units as follows:

- channel path identifier `n0xx` represents the channel `xx` in server n ($n = 1, \dots, 9, A, \dots, F$)
- channel path identifier `00xx` or `xx` is used as a general channel for all Server Units.

The statements `CHN`, `CTL` and `DVC`, extended by this new assignment, are used to define hardware units.

In the case of the `CHN` statements, all `n0xx`, `00xx` and `xx` channels for the Server Unit n are evaluated, all others are ignored as “remote channels”.

In the case of the `CTL` statements, the attachments relating to “remote channels” are removed from the controllers described. Controllers on “remote channels” alone are completely ignored.

In the case of `DVC` statements, the devices on “remote controllers” (only connected to other Server Units) are removed from the devices described.

A precondition for this is that the `CTL` statements be specified **before** the associated `DVC` statements in the sequence of statements for the IOGEN run.

Furthermore, the `PREP` operand for “remote channels” is filtered out in `DVC` statements. The filter operation is performed for each statement (`CHN`, `CTL`, `DVC`). The customary checks are then performed.

Example of a network generation

For the sake of clarity, this example contains a small extract from an I/O configuration. The advantage of an IOGEN description for two or more Server Units only becomes obvious in a large configuration with several shared disk peripherals.

The generation for Server Unit 2 is started using `/START-IOGEN . . . , SELECT=2`.

```
*****
* SERVER UNIT 1: SU700-1
* SERVER UNIT 2: SU700-2
*****
CPGOPT REPLACE=YES
*****
* SYSTEM 1: CHN 1XXX, 0XXX, XX
*****
GEN IOCONF,NAME=SU700-1
CPU SE
```

```

IOCFID 'SU700-1 / EXAMPLE'
*****
* SYSTEM 2: CHN 2XXX, 0XXX, XX *
*****
GEN IOCONF,NAME=SU700-2 2.
CPU SE
IOCFID 'SU700-2 / EXAMPLE'
*****
* CHANNEL SYSTEMS 1 AND 2
*****
CHN 00,IBF,MODE=CNC * FCLINK NATIVE MODE 3.
CHN 40,IBF,MODE=FCP * MU DIRECT (KVP)
*****
* FCP CHANNELS * SYSTEM 1 *
*****
CHN 1008,IBF,MODE=FCP * HNC DIRECT 4.
CHN 100A,IBF,MODE=FCP * DISK
CHN 100B,IBF,MODE=FCP * DISK
CHN 100C,IBF,MODE=FCP * DISK
CHN 100D,IBF,MODE=FCP * DISK
*****
* FCP CHANNELS * SYSTEM 2 *
*****
CHN 2041,IBF,MODE=FCP * HNC DIRECT 5.
CHN 201A,IBF,MODE=FCP * DISK
CHN 201B,IBF,MODE=FCP * DISK
CHN 201C,IBF,MODE=FCP * DISK
CHN 201D,IBF,MODE=FCP * DISK

*****
* CONTROL UNIT HST *
*****
CTL HS,BLM,(00,0),CUADD=3F * CUADD 3F 6.
*****
* MU FCP CHANNEL 40 *
*****
CTL CC80,BLM,(40,0,0000000000000000) * DIRECT 7.
*****
* KVP MAIN-CONSOLE MONITOR SYSTEM *
*****
DVC C2,64,A,C3,(CC80)
DVC C3,64,A,C4,(CC80)
*****
*
*****
* HNC FCP CHANNEL 08 SYSTEM 1 *
*****
CTL CC00,BLM,(1008,0,0000000000000000) * DIRECT 8.
*****
DVC CC00,6D,A,0000,(CC00),MULT=2
*****
*
*****
* HNC FCP CHANNEL 41 SYSTEM 2 *
*****
CTL CD00,BLM,(2041,0,0000000000000000) * DIRECT 9.
*****
DVC CD00,6D,A,0000,(CD00),MULT=2
*****

```

```

*
*****
*   DISKS                                           *
*****
CTL 8001,BLM,(100A,0,5000097208132110),(100D,0,5000097208132124)    10.
CTL 8002,BLM,(201A,0,5000097208132110),(201D,0,5000097208132124)
CTL 8003,BLM,(100C,0,500009720813211C),(201B,0,5000097208132114)
CTL 5100,BLM,(100B,0,5000097208132515)
CTL 5101,BLM,(201C,0,5000097208132521)
*****
DVC 8000,A5,D,0000,(8001),(8002),(8003),MULT=64                    11.
DVC 5100,AA,D,000A,(5100),(5101),MULT=16
DVC 5110,AA,D,001A,(5100),MULT=16
DVC 5120,AA,D,002A,(5101),MULT=16
END

```

1. The GEN, CPU, IOCFID sequence of statements (to generate Server Unit 1) is ignored.
2. The second GEN statement (... , . . . , SELECT=2) and the CPU and IOCFID statements following it are evaluated.
3. Channel 00 is generated on both Server Units.
4. The statements for the “remote channels” (chn-path-id 1xxx) are ignored.
5. All chn-path-id 2xxx are replaced by 0xxx in the following statements.
6. This CTL statement is taken into consideration for both Server Units (since it refers to channel 00).
7. This CTL statement is taken into consideration for both Server Units (since it refers to channel 00), as are the DVC statements following it.
8. This CTL statement is ignored (because of the “remote channel 1008”), as are the DVC statements following it.
9. This CTL statement (on the non-remote channel) and the statements following it are executed.
10. The following applies for the CTL statements (here for disk controllers):
 - the statements for 8001 and 5100 are ignored (only with “remote channels”)
 - the statements for 8002 and 5101 are accepted (only with non-remote channels)
 - the attachments for “remote channels” are removed from the statement for 8003, which is then accepted
11. The attachments for “remote controllers” (8001 and 5100, see (10)) are removed from the available devices. This means that the devices 5110 through 511F connected solely via 5100 are omitted.

4.2.9 Customizing the BS2000 Control System

A hardware-dependent standard EXEC is supplied with BS2000 OSD/BC.

Changing the size of the virtual address space

In the standard EXEC of the BS2000 operating system the size of the virtual address space is pregenerated with 1808 MB of user address space. This results in 240 MB of system address space (SYSSIZE). The following procedure is supplied for adjusting this value:

```
SYSPRC.BS2000-EXEC.<ver>
```

Before the SYSPRC.BS2000-EXEC.<ver> procedure is called, the standard EXEC SYSPRG.BS2.<ver> must be copied to SYSPRG.BS2.<ver>.STD or renamed.

SYSPRG.BS2.<ver>.STD is the input file for the procedure.

The following SYSSIZE values can be set using the procedure. The procedure can also be used to change the program name of the standard EXEC.

Address space	MB ¹	MB	MB	MB	MB	MB
System address space set (<syssize>)	128	240	256	and so on, in steps of 16 MB	496	512
Resulting user address space	896	1808	1792	and so on, in steps of -16 MB	1552	1536
Resulting address space	1024	2048	2048	2048	2048	2048

¹ If necessary, input values are rounded up to a multiple of 16 MB

The name of the output file is: SYSPRG.BS2.<ver>.STD[.<syssize>][.<program_name>].

This output file must be renamed SYSPRG.BS2.<ver>, or its name must be specified in the BS2000 parameter file.



A specific EXEC generated by the procedure cannot be used as the input file for another procedure run.

So that the procedure can change the address space, the standard EXEC supplied contains additional modules that are not required for the actual execution of BS2000. These modules are not adopted when the modified EXEC is created, which is why the file with the newly created EXEC is approx. 25% smaller than the standard EXEC.

4.2.10 Statements for IOGEN

IOGEN statements enable users to control generation of the I/O configuration data according to their individual needs. A description of the functional application of the IOGEN statements can be found in the [section "Rules for generating the I/O configuration data"](#).

IOGEN statements consist of an operation field and an operand field. The operation field gives the statement name, which indicates the operation to be carried out. This field can contain any number of leading blanks.

The operand field can contain any number of operands, separated by commas. The first operand in the operand field must be separated from the statement name by at least one blank.

Keyword operands of a statement can be in any order, but keyword operands must not be specified before positional operands.

Commas indicating the absence of positional operands can be omitted if no further positional or keyword operands follow.

This rule also applies to operand groups in parentheses. The last operand can be followed by comments, which must be separated from the operands by at least one blank.

An IOGEN statement which is read in from a terminal or from a file must not exceed 1024 characters in length. An IOGEN statement which is read in from a file can contain any number of continuation lines, but must likewise not exceed a total of 1024 characters. If a line is to be continued, data is written up to column 71 and a hyphen (-) is entered in column 72 as a continuation character. The continuation line must begin in column 1.

The syntax display of the IOGEN statements is based on the SDF syntax (see the "Commands" manual [2]) with the following exceptions:

Notation	Meaning	Example
Lowercase letters	Lowercase letters denote variables, for which the user must enter appropriate values upon input, i.e. their contents may vary from one application to the next.	IOCFID 'text'
[]	Square brackets enclose optional entries, i.e. entries which may be omitted. (Parentheses must be specified!)	CPU base [, MODEL= ...]



This manual only describes components of the IOGEN statements which are relevant for Server Unit /390.

Control IOGEN run

Statement	Meaning
CPGOPT	Define generation options for IOGEN
END	Terminate IOGEN statements
GEN	Define program name
IOCFID	Define header text for IOCF

Statements for defining the hardware configuration

Statement	Meaning
CHN	Define channel
CPU	Define CPU
CTL	Define controller
DVC	Define device

General statements

Statement	Meaning
SYSFILE	Change assignment of the input medium
*	Insert comments

4.2.10.1 CHN - Define channel

The CHN statement (CHaNnel) defines the channel properties.

A CHN statement is required for each channel.

CHN
chn-path-id, type [,MODE=FCP/CNC]

chn-path-id

Channel path identifier.

Value: two or four hexadecimal digits, also combined in different CHN statements: 00 - FF or 0000 - 00FF.

type

Type of channel.

Value: IBF (Fibre Channel Protocol)

MODE

Mode in which the channel operates.

MODE=FCP

Channel operated with the FC-SCSI protocol

MODE=CNC

FCLINK channel (hardware test)

Examples

```
CHN F0,IBF,MODE=FCP
```

4.2.10.2 CPGOPT - Define generation options for IOGEN

The CPGOPT statement (Control Program Generator OPTions) defines the options for generating the IOCF file.

Several CPGOPT statements can be issued for the same IOGEN run. For operands that are specified more than once, it is the latest valid value that applies. No comma may be specified for the operand named first.

CPGOPT
[,REPLACE=Y / <u>N</u>]
[,PROT= <u>*FILE</u> / *PRINT / *SPOOL]

REPLACE

Controls overwriting of the SYSDAT.BS2.<ver>.IOCF[.<name>] and SYSDAT.IOGEN.<ver>.IOCF[.<name>] files. In this case <name> is the name from the GEN statement.

REPLACE=Y

The files are to be overwritten.

REPLACE=N

The files are not to be overwritten (default value).

I.e. generation is canceled if the SYSDAT.BS2.<ver>.IOCF[.<name>] file or the (temporary) file SYSDAT.IOGEN.<ver>.IOCF[.<name>] exists.

PROT

Controls the logging of the subroutine IOCGEN.

PROT=*FILE

The log of the IOCGEN run is output to the SYSLST.IOGEN.<ver>.IOCF[.<name>] file (default). If this file already exists then it is overwritten.

PROT=*PRINT

The log of the IOCGEN run is written to the current SYSLST file (after the IOGEN log). At the end of the program, a print job is created for the SYSLST file.

PROT=*SPOOL

The log of the IOCGEN run is written to the current SYSLST file (after the IOGEN log). You can control the use of the SYSLST file or permit control by the operating system for example, printing on /EXIT-JOB).

4.2.10.3 CPU - Define CPU

The CPU statement specifies the type of CPU involved. Only one CPU statement needs to be specified per hardware generation. There is only ever one CPU statement for a Server Unit, irrespective of the number of CPUs.

CPU
base

base

Specifies the CPU type. There is no prescribed default value.

Value: SE (Server Unit /390)

4.2.10.4 CTL - Define controller

The CTL statement (ConTroLler) defines a controller and its channel ports. Up to eight channel ports are possible.

CTL
ctl-mn, [type], (chn-path-id,ctl-no, [wwpn])
[(chn-path-id,ctl-no, [wwpn])]
[(chn-path-id,ctl-no, [wwpn])]
[(chn-path-id,ctl-no, [wwpn])]
[(chn-path-id,ctl-no, [wwpn])]
[(chn-path-id,ctl-no, [wwpn])]
[(chn-path-id,ctl-no, [wwpn])]
[(chn-path-id,ctl-no, [wwpn])]
[(CUADD=3F)]

ctl-mn

Mnemonic name of the controller.

Value: two alphanumeric characters (A...Z, 0...9) or four hexadecimal digits 1000 <= ctl-mn <= FFFF

type

Operating mode of the controller.

Value: BLM for all controllers (default value).

chn-path-id

Channel path identifier of the channel to which the controller is connected.

Value: channel path identifier as specified in the associated CHN statement. For a description of the CHN statement, see "[CHN - Define channel](#)".

ctl-no

Physical controller number.

Value: Controllers connected to channel type `IBF, MODE=FCP`: only 0

wwpn

World-Wide Port Number (target ID) of the controller port if the controller is connected to a channel with the FC-SCSI protocol.

Value: 16 hexadecimal digits

CUADD=3F

Mandatory specification only for the controller connected to FCLINK channel 00 for the hardware test, see [section "Configuration for the hardware test"](#).

Notes

- Concurrent operation of disk and tape devices on the same channel can cause considerable disturbances in disk I/O operations.
- Multiple logical controllers must be defined for a controller with more than 256 device ports on channel type `IBF`, `MODE=FCP`. A separate CTL statement with a different CTL mnemonic must be used for each logical controller. See the example on "[Creating device addresses](#)".

4.2.10.5 DVC - Define device

The DVC statement (DeViCe) defines the devices of an I/O configuration. A DVC statement is normally required for each device.

Several DVC statements must be specified if the following devices are connected (for device type codes, see "[Device type table](#)):

- Console devices (device type code 64), see "[Configuration of the Management Unit \(MU\)](#)"
- Network and LOCLAN devices (device type code 6D), see "[Configuration of the Management Unit \(MU\)](#)" and "[Network configuration](#)"

DVC
dvc-mn, type, [<u>A</u> / D], lun, (ctl-mn)
[(ctl-mn)] [(ctl-mn)] [(ctl-mn)] [(ctl-mn)] [(ctl-mn)] [(ctl-mn)] [(ctl-mn)]
[,PREP=chn-path-id]
[,MULT=n]
[,PAV=pav-addr]

dvc-mn

Mnemonic device name.

Value: two alphanumeric characters (A...Z, 0...9) or four hexadecimal digits $1000 \leq \text{dvc-mn} \leq \text{FFFF}$ (see [section "General conditions for hardware generation"](#)).

type

Device type code.

Value: see "[Device type table](#)".

A

Specifies that the device is available to the system (ATTACHED, default value);

D

Specifies that the device is not available to the system (DETACHED).

lun

Logical Unit Number of a device on the channel.

Value: two or four hexadecimal digits.

(ctl-mn)

The operand group in parentheses must be specified more than once if the device is accessible within the server via multiple controllers.

Up to eight controller ports and up to eight access paths are possible.

Value: mnemonic name of the controller as used in the assigned CTL statement.

PREP=chn-path-id

Channel path identifier of the channel via which the device is to receive privileged service during I/O operations. This should only be specified if the device can be accessed via more than one channel. By default, the privileged channel is selected with the help of a defined algorithm.

MULT=n

Group declaration for devices.

One statement defines “n” devices with the mnemonic device names `dvc-mn` through `dvc-mn + n-1` and the Logical Unit Numbers from `lun` through `lun + n-1`.

In the case of alias devices (PAV), all alias addresses from `pav-addr` through `pav-addr + n-1` are created. Alias addresses must be different from the low-order bytes of the Logical Unit Numbers of non-alias devices with the same controller ports.

This operand is permitted with two- and four-character mnemonics. In the case of two-character mnemonics, the subsequent mnemonics are created in ascending lexicographical order, in other words letters before digits (A, B, ..., Z, 0, 1, ..., 9).

PAV=pav-addr

Defines a PAV alias device.

`pav-addr` is the alias address of the alias device.

It must be different from the low-order byte of the `lun`.

It must also be different from the low-order byte of the `lun` of all non-alias devices with the same controller ports.

It must also be different from the alias addresses of other alias devices with the same controller ports.

Value: Two hexadecimal digits.

Example of a configuration with alias devices

```
*****
*   CHN                                     *
*****
CHN 08,IBF,MODE=FCP          * DISK D3435
CHN 0A,IBF,MODE=FCP          * DISK D3435
*****
*   DISK D3435 (CHN 08 + 0A)               *
*****
*
*WWPN 500000E0D4011180 <> CM0/PORT0
*WWPN 500000E0D4011190 <> CM1/PORT0
*
CTL F000,BLM,(08,0,500000E0D4011180)
CTL F001,BLM,(0A,0,500000E0D4011190)
*   LUN 0000 - 007F
DVC F000,A5,D,0000,(F000),(F001),MULT=128      * BASE:  F000-F07F
DVC F080,A5,D,0000,(F000),(F001),PAV=80,MULT=128 * ALIAS:  F080-F0FF
```

Notes

4.2.10.6 END - Terminate IOGEN statements

The END statement terminates the input of all IOGEN statements.

END

i If the end criterion `EOF` is detected when reading in the IOGEN statements without the END statement having been issued, recourse is made to the preceding input medium if this is available (as for `SYSFILE SYSDTA=(LAST)`). If 'EOF' is detected in the primary input source without the END statement having been issued, the messages `NGC0A36` and `NGC0A42` are output. Generation is continued with the data of the statements read in so far.

4.2.10.7 GEN - Define program name

The GEN statement (GENerate object) defines the program name. It can occur anywhere in the statement sequence. It can be omitted if the default names are to be used. If multiple GEN statements are issued, the first correct GEN statement is valid.

In the case of network generation, the GEN statement initiates the associated CPU and IOCFID statements.

GEN
[NAME=name]

NAME=name

Alphanumeric string which can be divided into several partial strings separated by a hyphen; first character: A...Z; maximum of eight characters.

Character set: A...Z, 0...9, \$, #, @, - (hyphen)

name has the following meanings:

- Program name for the generated objects
Default value: IOV<ver>
- Part of the file name of the I/O configuration file SYSDAT.BS2.<ver>.IOCF.<name>
Default value for the file name: SYSDAT.BS2.<ver>.IOCF
- Part of the file name of the log file SYSLST.IOGEN.<ver>.IOCF.<name>
Default value for the file name: SYSLST.IOGEN.<ver>.IOCF
- Part of the file name of the temporary file SYSDAT.IOGEN.<ver>.IOCF.<name>
Default value for the file name: SYSDAT.IOGEN.<ver>.IOCF

name is also entered in the IOCF comment field (first eight characters from the comment which can be entered using the IOCFID statement). It is also displayed using the /SHOW-IOCF command, see the "Commands" manual [2].

name can also be used for the hardware-dependent selection of the parameter file by startup, see "[startup files](#)".

4.2.10.8 IOCFID - Define header text for IOCF

The IOCFID statement (Input/Output Configuration File Identifier) defines a text field which is transferred to the data set identification block (DSID) of the IOCF and taken over as the header in the IOCF configuration report.

IOCFID
'text'

'text'

Header text serving to identify the IOCF configuration report and title serving to identify the IOCF.

The text must be enclosed in single quotes and may have up to 56 characters.

Notes

- This statement is optional. If it is specified several times, only the last one is evaluated.
- If the NAME operand of the GEN statement was used, its value is entered in the first eight bytes of the IOCF comment field in the DSID, otherwise the default value `IOV<ver>` is entered. It is used for the automatic selection of the parameter file by startup. This entry is made even if the IOCFID statement is not used.
- The text of the IOCFID statement is entered after the first eight bytes of the IOCF comment field.

4.2.10.9 SYSDTA - Change assignment of input medium

The SYSDTA statement (system file) changes the assignment of the input medium from which the IOGEN statements are read. The maximum number of files which can be processed by SYSDTA statements is 255.

SYSDTA
SYSDTA=filename / (LAST) / (PRIMARY)

SYSDTA=filename

Specifies the name of a cataloged SAM or ISAM file which is to be read by the IOGEN statements.

SYSDTA=(LAST)

Further IOGEN statements are preceded by the SYSDTA statement of the previous input medium.

SYSDTA=(PRIMARY)

All further IOGEN statements are read from SYSDTA=*PRIMARY.

Notes

- The SYSDTA statement can be specified as the first statement for an IOGEN run.
- Further SYSDTA statements can be input via the specified input medium. This enables the user to input all the IOGEN statements in succession from different input media. To prevent the risk of loops, no more than 10 nested SYSDTA statements may be specified. The SYSDTA statement cannot reference a file which has already been assigned.
- Input from SYSDTA is terminated when the end condition 'EOF' is given by SYSDTA or when an END statement is encountered.
- If an end condition is encountered, the next record is read from the file from which the last SYSDTA statement was read.
If the record was read from SYSCMD, input is terminated.

4.2.10.10 * Insert comments

The * statement enables comments and headers to be inserted in the IOGEN listing.

*
text

text

Any character string.

5 Installation services

- [Disk organization with pubsets](#)
- [The software product SIR](#)

5.1 Disk organization with pubsets

Pubsets (public volume sets, PVS) are sets of shared volumes and are used in BS2000 together with private volumes and Net-Storage for storing files (see also the “Introduction to System Administration” [4]).

Pubset is the general name for a set of disks irrespective of the pubset type (SF or SM pubset).

A pubset is identified by a unique pubset identifier (or pubset ID). A pubset is addressed by the user for the purposes of file access using its (syntactically identical) catalog ID (or catid).

The DMS function Multiple Public Volume Sets (MPVS) supports the use of several independent pubsets in a single BS2000 system. Management information on the various pubsets of a system is stored in the MRS catalog MRSCAT.

There is a “preferred” pubset (home pubset) which is required for loading, operating and shutting down the system and which must be available throughout the entire session.

In addition to this home pubset, it is possible to import other pubsets. The disks of an imported pubset are regarded as a single unit by the system and managed as such. By calling on the logical DMS functions, users can create, process and delete files and job variables on an imported pubset, provided they are authorized to do so.

Home pubset

This pubset contains the files required for startup (and automatic restart) (see the “Introduction to System Administration” [4]).

A home pubset is imported automatically during BS2000 system initialization.

Standby pubset

This pubset (catid STBY) is pregenerated in all SE servers and located on an internal disk (D0) which is working even without active SAN connection to other disks. It contains a preinstalled emergency system which may be used for installing or repairing the home pubset. However, the emergency system is not suitable for productive use.

Reserve pubset

This pubset, which contains the same files as the home pubset, can carry out the functions performed by the home pubset when the home pubset fails, i.e. the BS2000 operating system can be loaded and operated from this standby pubset.

In contrast to the standby pubset a reserve pubset allows not only installing or repairing the home pubset, it also allows immediate continuation of productive use during ongoing recovery of the home pubset.

Shared pubset (SPVS)

If the software product HIPLEX MSCF and a suitable hardware configuration are used, simultaneous access to a shared pubset is possible from more than one system.

Up to 16 systems linked in a shared HIPLEX MSCF network can access this shareable pubset as “sharers” via a direct hardware path. One of the participants in the network is designated the temporary owner of this pubset and handles the functions for file, user and access management for the other sharers. All management requests from subordinate participants (“pubset slaves” or “slave sharers”) must be forwarded to the owner (“pubset master”) via HIPLEX MSCF.

If the pubset master crashes, a pubset-specific job variable (see the “Job Variables” manual [9]) is set on all pubset slaves. In this case, one of the current pubset slaves can take over the role of the pubset master without having to export the pubset because of this. If this so-called master switch is not configured or fails, systems support must either export the pubset to all the remaining pubset slaves or (after the problem has been corrected) declare one of the remaining pubset slaves to be the new pubset master by means of `/IMPORT-PUBSET . . . ,SHARER-TYPE=*MASTER(MASTER-CHANGE=*YES)`.

The whole concept of shared pubsets (hardware configuration, pubset management, data access) is described in detail in the “HIPLEX MSCF” manual [7].

Paging pubset

During the session the paging area can be dynamically extended (`/EXTEND-PAGING-AREA`). It is essential here that the associated pubset is imported and the maximum size of the paging area (4 TByte) is observed.

Pubset organization

In order to use pubsets efficiently, the following disk organization is recommended:

- A pubset must be ready to be used as the home pubset. In other words all the users authorized to access the system must be entered in the user catalog for this pubset (LOGON validation via the home pubset). This pubset generally corresponds to the one created as a result of system installation.
- It is possible to install a second pubset as a reserve, so that the session can be continued on this reserve pubset should the home pubset crash.
- All the user files should be distributed over further pubsets. In this context, one of these pubsets is assigned to each user as the user default pubset.
- The paging files should be distributed over several pubsets, but should not be located on pubres, the first disk of a pubset.
- A paging area of at least 200 Mbytes should be set up in the home pubset.

Recommended disk organization

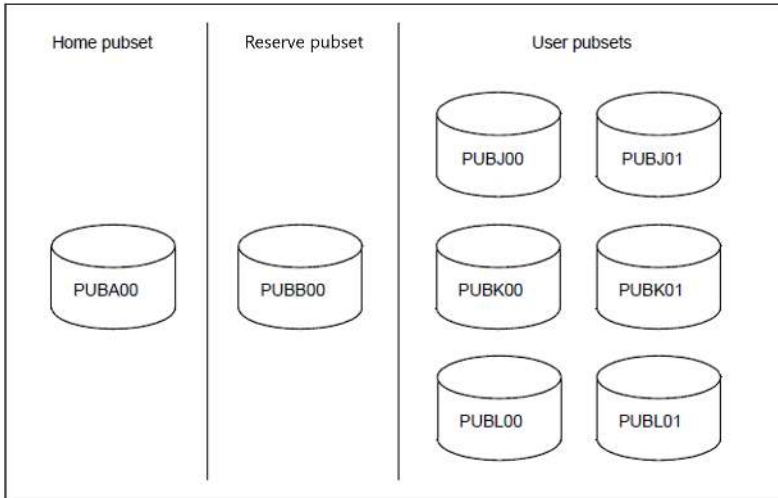

Figure 6: Disk organization with pubsets

- One disk (PUBA00) forms the home pubset.
 - One disk (PUBB00) forms the reserve pubset.
- In all configurations it is important to ensure that the home pubset and the reserve pubset do not reside on the same disk storage unit.
- Three further user pubsets (here: SF pubsets J, K and L) are set up in addition on the disks PUBJ00 and PUBJ01, PUBK00 and PUBK01, PUBL00 and PUBL01.
 - Further pubsets can be set up; these have to be imported when required.
 - Up to “system ready”, at least one paging file is needed in the home pubset. Paging files on the pubsets J, K and L either can be specified in the BS2000 parameter file for startup, or can be added from “system ready”, e.g. via the CMDFILE.
 - The home pubset is always the default pubset of the TSOS user ID. All standard files that are required for fast startup and automatic restart, for example, are to be stored on this pubset. The home pubset should not be assigned to any user as the default pubset, but should only contain the files of all system identifiers.
 - Since the reserve pubset is to assume the home pubset function, it must contain the same files as the home pubset. The reserve pubset should therefore not be assigned to any users as the default pubset and should, if possible, be used only by the operating system (reduced update requirements).
 - Since there is not just a single catalog, but one catalog for each pubset, the size of each catalog must be seen in relation to the size of the pubset or the file volume. The catalog size is influenced by:
 - the number of files that reside on the pubset
 - the number of private files cataloged in the pubset
 - the number of job variables that reside on this pubset.
 - TSOSCAT, MRSCAT and SYSSRPM are created during installation or `/IMPORT-PUBSET ACTUAL-JOIN=*FIRST, . . .`, without the user having any say in the matter (exception: TSOSCAT size).

The files on the pubsets may be distributed as follows:

Pubsets	Disks	Files
Home pubset	PUBA00	TSOSCAT SYSTEM.MRSCAT SYSTEM.MRSCAT.COPY SYSSRPM SYSEAM SYS.PAGING.PUBA00 startup files additionally: ID of system administration for current session all utility routines message files language processors libraries
reserve pubset	PUBB00	TSOSCAT SYSTEM.MRSCAT SYSTEM.MRSCAT.COPY SYSSRPM SYSEAM SYS.PAGING.PUBB00 startup files additionally: all files that are on the home pubset must be created and maintained on the standby pubset.

Pubsets	Disks	Files
User pubset	PUBJ00	<ul style="list-style-type: none"> • TSOSCAT • SYSSRPM
	PUBJ01	<ul style="list-style-type: none"> • SYS.PAGING.PUBJ01
	PUBK00	<ul style="list-style-type: none"> • TSOSCAT • SYSSRPM
	PUBK01	<ul style="list-style-type: none"> • SYS.PAGING.PUBK01
	PUBL00	<ul style="list-style-type: none"> • TSOSCAT • SYSSRPM
	PUBL01	<ul style="list-style-type: none"> • IPL files (optional)
		<p>in addition:</p> <ul style="list-style-type: none"> • user/file distribution organized according to areas of activity

Structure of /ADD-USER for the user ID COMPILER and four users:

- Entries for the home pubset A:

```

/ADD-USER USER-ID=COMPILER,...,PUBSET=A,DEFAULT-PUBSET=A, ...
/      ...,PUBLIC-SPACE-LIMIT=n
/ADD-USER USER-ID=USER1,...,PUBSET=A,DEFAULT-PUBSET=J, ...
/      ...,PUBLIC-SPACE-LIMIT=0
/ADD-USER USER-ID=USER2,...,PUBSET=A,DEFAULT-PUBSET=K, ...
/      ...,PUBLIC-SPACE-LIMIT=0
/ADD-USER USER-ID=USER3,...,PUBSET=A,DEFAULT-PUBSET=K, ...
/      ...,PUBLIC-SPACE-LIMIT=0
/ADD-USER USER-ID=USER4,...,PUBSET=A,DEFAULT-PUBSET=L, ...
/      ...,PUBLIC-SPACE-LIMIT=0

```

- Entries for the reserve pubset B:

```
/ADD-USER USER-ID=COMPILER,...,PUBSET=B,DEFAULT-PUBSET=B, ...  
/      ...,PUBLIC-SPACE-LIMIT=n  
/ADD-USER USER-ID=USER1,...,PUBSET=B,DEFAULT-PUBSET=J, ...  
/      ...,PUBLIC-SPACE-LIMIT=0  
/ADD-USER USER-ID=USER2,...,PUBSET=B,DEFAULT-PUBSET=K, ...  
/      ...,PUBLIC-SPACE-LIMIT=0  
/ADD-USER USER-ID=USER3,...,PUBSET=B,DEFAULT-PUBSET=K, ...  
/      ...,PUBLIC-SPACE-LIMIT=0  
/ADD-USER USER-ID=USER4,...,PUBSET=B,DEFAULT-PUBSET=L, ...  
/      ...,PUBLIC-SPACE-LIMIT=0
```

Entries in the user catalog are in “back-to-front” order to the home pubset. As a result of this, it is not necessary to make any modifications when pubset B is used for loading.

- Entries for user pubset J:

```
/ADD-USER USER-ID=USER1,...,PUBSET=J,...,PUBLIC-SPACE-LIMIT=n  
/ADD-USER USER-ID=USER4,...,PUBSET=J,...,PUBLIC-SPACE-LIMIT=0
```

If the system parameter FSHARING=0 (default setting), entering USER4 with space limit 0 is necessary on pubset J in order to grant this user access to shareable files of other users located on this pubset (USER2 and USER3 cannot do this). If FSHARING=1 is set in the BS2000 parameter file, all users are granted access (and no catalog entry for USER4 with space limit 0 is required).

- Entries for user pubset K:

```
/ADD-USER USER-ID=USER2,...,PUBSET=K,...,PUBLIC-SPACE-LIMIT=n  
/ADD-USER USER-ID=USER3,...,PUBSET=K,...,PUBLIC-SPACE-LIMIT=n
```

- Entries for user pubset L:

```
/ADD-USER USER-ID=USER4,...,PUBSET=L,...,PUBLIC-SPACE-LIMIT=n
```

The system finds the default allocations of the individual users by the entries in the current home pubset. When a file is addressed via ‘\$userid.’, the file is sought in the pubset that is the default pubset for ‘userid’.

/ADD-USER is described in the “Commands” manual [2].

Notes on organizational division:

- Paging files outside the home pubset for startup are specified in the BS2000 parameter file.
- When the system is in operation, the paging area can be extended with /EXTEND-PAGING-AREA.
- The entries in the user catalog should be up-to-date and should be saved regularly (see the “Introduction to System Administration” [4]).
- The startup parameter service can be called with the help of the dialog startup in order to change the default values (see the “Introduction to System Administration” [4]).

Advantages of this disk organization

- Reliability

- Failure of the IPL on PUBA00:

By virtue of a double IPL (IPL also on PUBB00) or a triple IPL (IPL also on PUBB00 and PUBL01), the system can be loaded at any time.

- Failure of the user/file catalog or the entire pubset A:

By distributing the entries in the user catalog judiciously (“back to front”) over PUBB00 and selectively updating the files and catalog entries maintained there, the system can be loaded via PUBB00 at any time without impairing operation for the user.

- Failure of pubset L (without paging):

The system can continue to be used. Only USER4 will be affected in his work.

- Failure of pubset B (reserve pubset):

The system can continue to be used as usual. The reserve pubset can be reconstructed online.

- Version changeover

A system of the new version can be created on pubset B under the BS2000 operating system from pubset A. Pubset X can then be appended to the current system by means of `/IMPORT-PUBSET ACTUAL-JOIN=*FIRST`. After all required files or procedures have been readied (online), a startup of the new version can be effected. If the changeover is not successful, the loadable pubset A ready for operation is available as a fallback solution, i. e. the downtime of the system is reduced to a minimum.

i A “first start” is not necessary if SIR had already imported the pubset using `ACTUAL-JOIN=*FIRST`, e.g. in order to create paging files or to copy files onto it. In this case `/IMPORT-PUBSET ACTUAL-JOIN=*FIRST` is already performed under SIR.

5.2 The software product SIR

The software product SIR (System Install and Restore) is used to install a pubset during system installation or in ongoing operation.

In addition, SIR offers facilities for initializing disks (VOLIN utility routine).

In general, each SIR version is linked to a particular BS2000 version. This means that a given version of SIR can only generate IPL disks and BS2000 systems of exactly the version it is linked to.

A version changeover is an exceptional case in this context: The SIR version linked to the desired new BS2000 version (target version) needs to run in the existing old BS2000 version (execution version).

SIR provides compatibility only backwards here, i.e. it must always be execution version \leq target version. It is therefore recommended to keep a suitable home pubset or IPL disk, in case you might need to return to an earlier version in the future.

In BS2000 V21.0, a version changeover can be based on the **execution versions BS2000/OSD-BC V10.0 or V11.0**. The software package BS2OS.MIGRATE must be installed for doing so, which contains e.g. the appropriate version of SIR for creating IPL disks of BS2000 V21.0.

You should bear in mind that only device types belonging to the device spectrum of BS2000 (both in the execution version and in the target version) are supported.

For a detailed description of the SIR utility routine see the "Utility Routines" manual [1].

6 Handling important system files

The following files are protected against migration by HSMS via the file attribute `MIGRATE=*INHIBIT` or `*FORBIDDEN`:

- files required to load BS2000
- files of the optional subsystems (RSO, ...)
- important files of products of the software configuration (SYSLNK., SYSLIB., ...).

Migration protection should not be changed except for important reasons (`/MODIFY-FILE-ATTRIBUTES` operand `MIGRATE`).

Further files can be excluded from migration by writing their names into a file which then is defined as an except file in HSMS using the following HSMS statement (see the “HSMS” manual [8]):

```
//MODIFY-HSMS-PARAMETERS MIGRATION-CONTROL=*PARAMETERS(EXCEPT-FILE=filename)
```

The following sections briefly describe the system files which can be created or have their size or position modified in the course of system installation (see the “Introduction to System Administration” [4]).

6.1 Startup files

The generated BS2000 operating system on its own is not a loadable unit. It must be loaded by bootstrapping via other files. The same applies for the dump generator SLED.

The following startup files which are created by SIR are available, anchored in the SVL of the IPL disk:

SYSPRG.BOOT. DSKnnn.SAVE	Save area for IPL
SYSPRG.IPL. DSKnnn	IPL routine, initialization routine for EXEC, SLED dump routine (orig.SYSPRG/SKMPRG.IPL.<ver>)
SYSREP.IPL. DSKnnn	Object corrections for IPL(orig.SYSREP.IPL.<ver>)
SYSPRG.SLED. DSKnnn.SAVE	Save area for SLED
SYSREP.SLED. DSKnnn	Object corrections (REPs) for SLED (orig.SYSREP.SLED.<ver>)
SYSDAT.IPL- CONF.DSKnnn	Save area for the startup configurations (created by SIR). Several startup configurations, even from different servers, can be stored in this file.

At startup, these files are searched for on the disk via address chaining only. Address chaining is performed in the standard volume label (SVL) of the IPL disk by the appropriate SIR run (see the "Utility Routines" manual [1]).

The "nnn" in DSKnnn stands for the nnn-th disk of the pubset. During the SIR run, the SYSPRG/SKMPRG.IPL.<ver>, SYSREP.IPL.<ver> and SYSREP.SLED.<ver> delivery files are copied to the appropriate DSKnnn files. DSKnnn is replaced by vsn in private disks.

The DSKnnn files must not be copied or relocated (e.g. in the course of reorganization measures), since the only way they can be referenced during startup is via pointers in the SVL. SIR catalogs them at backup level 'E' before address chaining is carried out. This excludes them from implicit save operations (e.g. ARCHIVE), but the delivery files are backed up and restored by ARCHIVE. To protect these files against migration by HSMS, they have the file attribute MIGRATE=*FORBIDDEN.

Address chaining (see above) must be carried out to update these files (see above).

If several IPL disks are installed within one pubset in order to increase availability, the file names must be different, regardless of the content of the data objects. SIR guarantees this via the disk-specific file name suffix DSKnnn.

If CREATE-IPL-VOLUME or MODIFY-IPL-VOLUME is specified for a pubset, SIR creates the SYS.NSI.SAVEREP file in order to save system corrections during system initialization.

The table lists the files which should be present on the home pubset under the TSOS ID in addition to the startup files anchored in the SVL.

File name	Utilization
<code>SYSPRG/SKMPRG.STRT.<ver></code>	Load object SYSSTART
<code>SYSREP.STRT.<ver></code>	Object corrections for SYSSTART
<code>SYSREP.BS2.<ver></code>	Object corrections (REPs) for BS2000 ¹
<code>SYSPAR.BS2.<ver></code>	Parameter settings ¹
<code>SYSPRG.BS2.<ver></code>	Load object "BS2000 CLASS1/2 EXEC" ¹

¹ These file names can be modified via the startup parameter service

Automatic selection of the parameter file by startup

If a system is to be operated on alternating Server Units, a different parameter file can be used depending on the Server Unit involved.

Automatic selection of this parameter file is implemented by BS2000 in FAST and AUTOMATIC startup and in DIALOG startup when the standard parameter file is selected (entry of P.) in the following sequence:

- In Native mode and in the VM2000 monitor system:
 1. the `$TSOS.SYSPAR.BS2.<ver>.<name>` file (for SU /390).
`<name>` is the value of the `NAME` operand from the `GEN` statement of `IOGEN` which is entered in the first eight characters of the `IOCF` comment field of the active `IOCF` (see "[GEN - Define program name](#)").
 2. the `$TSOS.SYSPAR.BS2.<ver>.<system-name>` file (for SU x86).
`<system-name>` is the system name that was assigned in the BS2000 configuration (option `auto IPL`). It can still be changed in the `IPL` menu (dialog screen of the SE manager or `SVP` menu of the allocated `KVP` console).

i `<name>` and `<system-name>` must be different when different parameter values are to be defined for the Server Units.

- in a VM2000 guest system:
 1. The file `$TSOS.SYSPAR.BS2.<ver>.<vm-name>` (for SU /390 and for SU x86, if the guest system is booted via `/START-VM`).
`<vm-name>` is the VM name of the guest system.
 2. The file `$TSOS.SYSPAR.BS2.<ver>.<system-name>` (for SU x86, if the guest system is not booted via `/START-VM`).
`<system-name>` is the system name that was assigned either for the persistent VM (option `auto IPL`) or entered/changed in the `IPL` menu (dialog screen of the SE manager or `SVP` menu of the allocated `KVP` console).

i If the guest system is booted on SU x86 using `/START-VM`, the system name will be matched to the VM name.

- If no specific parameter file is found, the file with the default name `$TSOS.SYSPAR.BS2.<ver>` is searched for.
- If none of the above-mentioned parameter files is found, a FAST or AUTOMATIC startup is interrupted and DIALOG startup is switched to while the parameter is read in.

6.2 File catalog TSOSCAT

The file catalog TSOSCAT is located on every pubset together with an MRSCAT entry for the user's own pubset. TSOSCAT contains the administrative information on files (see the "Introduction to System Administration" [4]).

The TSOSCAT file is set up by means of the SIR statement `//CREATE-CATALOG` when a new pubset is created.

6.3 Paging area

The paging area is the sum of all `SYS.PAGING.<vsn>` files. The paging area acts as an external storage area for non-resident areas of memory (see the “Introduction to System Administration [4]).

The disk area used for paging (paging file) is set up by means of the `SIR //CREATE-PAGING-FILE` statement or using the `/CREATE-PAGING-FILE` command.

6.4 SYSEAM files

The SYSEAM system files contain all the users' EAM files (system work files), see the "Introduction to System Administration" [4].

The name of a SYSEAM file is defined when a pubset is imported. A home pubset is imported during the startup phase.

6.5 User catalog

The user catalog contains the user entries (user ID, account number, password, mailing address etc.) on all users with system access authorization. It is generated during a first start (see the “Introduction to System Administration” [4]).

7 Appendix

- [Disk organization](#)
- [Device type table](#)
- [Volume type table](#)
- [Allocation table: mnemonic name - device number](#)

7.1 Disk organization

Meaning of the columns:

- 1 Device type as it is to be specified in BS2000 commands
- 2 Product name of the disk storage unit
- 3 Device type code
- 4 Change in utilization in the case of 2K when using PAM keys
 - N requires no formatting
 - Y requires formatting
- 5 Utilization:
 - K with PAM keys
 - NK without PAM keys
- 6 Minimum transfer unit between disk and main memory
- 7 Net capacity in 2 Kbyte units (PAM blocks) per volume
- 8 Track format

1	2	3	4	5	6	7	8
D3435	Disks in standard FBA format ^{1 2}	A5	N	K	2K	variable	FBA
				NK	2K	variable	FBA

Table 1: Disk organization

- 1 These disks with standard FBA format are visible for BS2000 as disks with a block size of 512 bytes, e.g. disks connection to the channel of the Server Unit /390, external disks connected to the Server Unit x86.

The following should be noted on the Server Unit / 390:

The internal disks with the preinstalled standby system are also displayed as D3435 disks in the BS2000. In contrast to the real D3435 disks, BS2000 can neither format nor initialize the D3435 internal disks.

Because the internal D3435 disks are built into the MU, they can be identified by the fact that they are generated on one of the channels 40 or 09 reserved for the MUs. Genuine D3435 disks are always connected through other channels.

- 2 These disks are preformatted. VOLIN simply provides them with labels.
 For Server Unit x86: The size and BS2000 format (K, NK2, NK4) must be defined in X2000 regardless of the preformatting and prior to initialization with VOLIN (see the "Operation and Administration" manual [5]).
 Following configuration of the disk under X2000, an initialization run should always be performed using VOLIN to avoid possible discrepancies.

Notes

- Changing the transfer unit always means that formatting is required.
- Changing the allocation unit without a change of the TU is always possible without formatting.
- The following entries are only permissible for public volumes:

```
FORMAT=NK ( PHYSICAL-BLOCK-SIZE=2K ( ALLOCATION-UNIT=8 ) )
```

```
FORMAT=NK ( PHYSICAL-BLOCK-SIZE=2K ( ALLOCATION-UNIT=64 ) )
```

7.2 Device type table

The table below contains all the codes required for the BS2000 operating system. For information on which devices are currently supported, please refer to the Release Notice.

Device family	Family name	F-C ¹	T-C ¹	Device type	Device / Product designation
BS2000 consoles	CONSOLE	00			Virtual consoles, see the "VM2000" manual [13]
			64	SKP2	Controller emulated for console operation
Network	TD	60	6D	HNC	Network devices on HNC (SU /390) LOCLAN devices on MU (SU /390) Network/LOCLAN devices connected/emulated via X2000 (SU x86)
Disk storage devices	DISK	A0	A5	D3435	
			A6	D3435-FP	FastDPAV alias devices ⁵
			AA	STDDISK	Standard disk type ² (internal type code AA00)
Tape devices	TAPE	C0/E0			
Magnetic tape cartridge devices	MBK	C0	C4	3590E	3590 (ETERNUS CS)
			CE	LTO-U4 ³	LTO-Ultrium 4
			CF	LTO-U5	LTO-Ultrium 5
			D1	LTO-U6	LTO-Ultrium 6
			D2	LTO-U7	LTO-Ultrium 7
			D3	LTO-U8	LTO-Ultrium 8
Bimodal tape devices	BIMTAPE	E0	E8	BM1662FS	Emulated tape drive on the basis of a CD/DVD drive or a file ⁴

Table 2: Device type table

- 1 F-C = family code; T-C = device type code
- 2 Each disk type code can be replaced by the standard disk type code AA to facilitate the changeover of disk controllers and disk devices. The exact disk type is determined dynamically during the attachment operation. See also [section "Disk device configuration"](#).
- 3 Also for virtual volumes in the ETERNUS CS virtual archive system.
- 4 The Management Unit's DVD drive is operated as an emulated tape device.

- 5 FastDPAV alias devices are to be generated with the disk type code A6, the general disk type code AA is not allowed.

7.3 Volume type table

Volume type code	Volume type	Meaning
A8	NETVOL	Net-Storage of type NETVOL in DMS commands and macros (there is no device type code for this)
A9	NETSTOR	Net-Storage volume in DMS commands and macros (there is no device type code for this)
B4	T6250 / T9G	(Emulated) long tape with a recording density of 6250 bpi (CD, DVD or file) (device type code: E8)
BB	TAPE-C3	36-track magnetic tape cartridge (device type code: C4)
BC	TAPE-C4	36-track magnetic tape cartridge, compressed (device type code: C4)
C1	TAPE-U8E	6656-track magnetic tape cartridge. Data is written in encrypted form (device type code: C1)
C7	TAPE-U4E	896-track magnetic tape cartridge. Data is written in encrypted form, see the "MAREN" manual [10] (device type code: CE)
C8	TAPE-U5E	1280-track magnetic tape cartridge. Data is written in encrypted form, see the "MAREN" manual [10] (device type code: CF)
C9	TAPE-U6E	2176-track magnetic tape cartridge. Data is written in encrypted form, see the "MAREN" manual [10] (device type code: D1)
CA	TAPE-U7E	3584-track magnetic tape cartridge. Data is written in encrypted form, see the "MAREN" manual [10] (device type code: D2)
CC	TAPE-U2	512-track magnetic tape cartridge (device type code: CC)
CD	TAPE-U3	704-track magnetic tape cartridge (device type code: CD)
CE	TAPE-U4	896-track magnetic tape cartridge Data is written in unencrypted form, see the "MAREN" manual [10] (device type code: CE)

CF	TAPE-U5	1280-track magnetic tape cartridge Data is written in unencrypted form, see the "MAREN" manual [10] (device type code: CF)
D1	TAPE-U6	2176-track magnetic tape cartridge, data is written in unencrypted form, see the "MAREN" manual [10] (device type code: D1)
D2	TAPE-U7	3584-track magnetic tape cartridge. Data is written in unencrypted form, see the "MAREN" manual [10] (device type code: D2)
D3	TAPE-U8	6656-track magnetic tape cartridge. Data is written in unencrypted form, see the "MAREN" manual [10] (device type code: D3)

Table 3: Volume type table

7.4 Allocation table: mnemonic name - device number

The device number of the device must be set in the loading procedure for the Server Unit /390.

During generation, IOGEN derives the device number from the mnemonic name for each device.

The following table shows the allocation of all 2-character mnemonic names (in ascending order) to the device numbers.

0x	1x	2x	3x	4x	5x
00 : 0C30	10 : 0C70	20 : 0CB0	30 : 0CF0	40 : 0D30	50 : 0D70
01 : 0C31	11 : 0C71	21 : 0CB1	31 : 0CF1	41 : 0D31	51 : 0D71
02 : 0C32	12 : 0C72	22 : 0CB2	32 : 0CF2	42 : 0D32	52 : 0D72
03 : 0C33	13 : 0C73	23 : 0CB3	33 : 0CF3	43 : 0D33	53 : 0D73
04 : 0C34	14 : 0C74	24 : 0CB4	34 : 0CF4	44 : 0D34	54 : 0D74
05 : 0C35	15 : 0C75	25 : 0CB5	35 : 0CF5	45 : 0D35	55 : 0D75
06 : 0C36	16 : 0C76	26 : 0CB6	36 : 0CF6	46 : 0D36	56 : 0D76
07 : 0C37	17 : 0C77	27 : 0CB7	37 : 0CF7	47 : 0D37	57 : 0D77
08 : 0C38	18 : 0C78	28 : 0CB8	38 : 0CF8	48 : 0D38	58 : 0D78
09 : 0C39	19 : 0C79	29 : 0CB9	39 : 0CF9	49 : 0D39	59 : 0D79
0A : 0C01	1A : 0C41	2A : 0C81	3A : 0CC1	4A : 0D01	5A : 0D41
0B : 0C02	1B : 0C42	2B : 0C82	3B : 0CC2	4B : 0D02	5B : 0D42
0C : 0C03	1C : 0C43	2C : 0C83	3C : 0CC3	4C : 0D03	5C : 0D43
0D : 0C04	1D : 0C44	2D : 0C84	3D : 0CC4	4D : 0D04	5D : 0D44
0E : 0C05	1E : 0C45	2E : 0C85	3E : 0CC5	4E : 0D05	5E : 0D45
0F : 0C06	1F : 0C46	2F : 0C86	3F : 0CC6	4F : 0D06	5F : 0D46
0G : 0C07	1G : 0C47	2G : 0C87	3G : 0CC7	4G : 0D07	5G : 0D47
0H : 0C08	1H : 0C48	2H : 0C88	3H : 0CC8	4H : 0D08	5H : 0D48
0I : 0C09	1I : 0C49	2I : 0C89	3I : 0CC9	4I : 0D09	5I : 0D49
0J : 0C11	1J : 0C51	2J : 0C91	3J : 0CD1	4J : 0D11	5J : 0D51
0K : 0C12	1K : 0C52	2K : 0C92	3K : 0CD2	4K : 0D12	5K : 0D52
0L : 0C13	1L : 0C53	2L : 0C93	3L : 0CD3	4L : 0D13	5L : 0D53
0M : 0C14	1M : 0C54	2M : 0C94	3M : 0CD4	4M : 0D14	5M : 0D54

0N : 0C15	1N : 0C55	2N : 0C95	3N : 0CD5	4N : 0D15	5N : 0D55
0O : 0C16	1O : 0C56	2O : 0C96	3O : 0CD6	4O : 0D16	5O : 0D56
0P : 0C17	1P : 0C57	2P : 0C97	3P : 0CD7	4P : 0D17	5P : 0D57
0Q : 0C18	1Q : 0C58	2Q : 0C98	3Q : 0CD8	4Q : 0D18	5Q : 0D58
0R : 0C19	1R : 0C59	2R : 0C99	3R : 0CD9	4R : 0D19	5R : 0D59
0S : 0C22	1S : 0C62	2S : 0CA2	3S : 0CE2	4S : 0D22	5S : 0D62
0T : 0C23	1T : 0C63	2T : 0CA3	3T : 0CE3	4T : 0D23	5T : 0D63
0U : 0C24	1U : 0C64	2U : 0CA4	3U : 0CE4	4U : 0D24	5U : 0D64
0V : 0C25	1V : 0C65	2V : 0CA5	3V : 0CE5	4V : 0D25	5V : 0D65
0W : 0C26	1W : 0C66	2W : 0CA6	3W : 0CE6	4W : 0D26	5W : 0D66
0X : 0C27	1X : 0C67	2X : 0CA7	3X : 0CE7	4X : 0D27	5X : 0D67
0Y : 0C28	1Y : 0C68	2Y : 0CA8	3Y : 0CE8	4Y : 0D28	5Y : 0D68
0Z : 0C29	1Z : 0C69	2Z : 0CA9	3Z : 0CE9	4Z : 0D29	5Z : 0D69

6x	7x	8x	9x	Ax	Bx
60 : 0DB0	70 : 0DF0	80 : 0E30	90 : 0E70	A0 : 0070	B0 : 00B0
61 : 0DB1	71 : 0DF1	81 : 0E31	91 : 0E71	A1 : 0071	B1 : 00B1
62 : 0DB2	72 : 0DF2	82 : 0E32	92 : 0E72	A2 : 0072	B2 : 00B2
63 : 0DB3	73 : 0DF3	83 : 0E33	93 : 0E73	A3 : 0073	B3 : 00B3
64 : 0DB4	74 : 0DF4	84 : 0E34	94 : 0E74	A4 : 0074	B4 : 00B4
65 : 0DB5	75 : 0DF5	85 : 0E35	95 : 0E75	A5 : 0075	B5 : 00B5
66 : 0DB6	76 : 0DF6	86 : 0E36	96 : 0E76	A6 : 0076	B6 : 00B6
67 : 0DB7	77 : 0DF7	87 : 0E37	97 : 0E77	A7 : 0077	B7 : 00B7
68 : 0DB8	78 : 0DF8	88 : 0E38	98 : 0E78	A8 : 0078	B8 : 00B8
69 : 0DB9	79 : 0DF9	89 : 0E39	99 : 0E79	A9 : 0079	B9 : 00B9
6A : 0D81	7A : 0DC1	8A : 0E01	9A : 0E41	AA : 0041	BA : 0081
6B : 0D82	7B : 0DC2	8B : 0E02	9B : 0E42	AB : 0042	BB : 0082
6C : 0D83	7C : 0DC3	8C : 0E03	9C : 0E43	AC : 0043	BC : 0083
6D : 0D84	7D : 0DC4	8D : 0E04	9D : 0E44	AD : 0044	BD : 0084

6E : 0D85	7E : 0DC5	8E : 0E05	9E : 0E45	AE : 0045	BE : 0085
6F : 0D86	7F : 0DC6	8F : 0E06	9F : 0E46	AF : 0046	BF : 0086
6G : 0D87	7G : 0DC7	8G : 0E07	9G : 0E47	AG : 0047	BG : 0087
6H : 0D88	7H : 0DC8	8H : 0E08	9H : 0E48	AH : 0048	BH : 0088
6I : 0D89	7I : 0DC9	8I : 0E09	9I : 0E49	AI : 0049	BI : 0089
6J : 0D91	7J : 0DD1	8J : 0E11	9J : 0E51	AJ : 0051	BJ : 0091
6K : 0D92	7K : 0DD2	8K : 0E12	9K : 0E52	AK : 0052	BK : 0092
6L : 0D93	7L : 0DD3	8L : 0E13	9L : 0E53	AL : 0053	BL : 0093
6M : 0D94	7M : 0DD4	8M : 0E14	9M : 0E54	AM : 0054	BM : 0094
6N : 0D95	7N : 0DD5	8N : 0E15	9N : 0E55	AN : 0055	BN : 0095
6O : 0D96	7O : 0DD6	8O : 0E16	9O : 0E56	AO : 0056	BO : 0096
6P : 0D97	7P : 0DD7	8P : 0E17	9P : 0E57	AP : 0057	BP : 0097
6Q : 0D98	7Q : 0DD8	8Q : 0E18	9Q : 0E58	AQ : 0058	BQ : 0098
6R : 0D99	7R : 0DD9	8R : 0E19	9R : 0E59	AR : 0059	BR : 0099
6S : 0DA2	7S : 0DE2	8S : 0E22	9S : 0E62	AS : 0062	BS : 00A2
6T : 0DA3	7T : 0DE3	8T : 0E23	9T : 0E63	AT : 0063	BT : 00A3
6U : 0DA4	7U : 0DE4	8U : 0E24	9U : 0E64	AU : 0064	BU : 00A4
6V : 0DA5	7V : 0DE5	8V : 0E25	9V : 0E65	AV : 0065	BV : 00A5
6W : 0DA6	7W : 0DE6	8W : 0E26	9W : 0E66	AW : 0066	BW : 00A6
6X : 0DA7	7X : 0DE7	8X : 0E27	9X : 0E67	AX : 0067	BX : 00A7
6Y : 0DA8	7Y : 0DE8	8Y : 0E28	9Y : 0E68	AY : 0068	BY : 00A8
6Z : 0DA9	7Z : 0DE9	8Z : 0E29	9Z : 0E69	AZ : 0069	BZ : 00A9

Cx	Dx	Ex	Fx	Gx	Hx
C0 : 00F0	D0 : 0130	E0 : 0170	F0 : 01B0	G0 : 01F0	H0 : 0230
C1 : 00F1	D1 : 0131	E1 : 0171	F1 : 01B1	G1 : 01F1	H1 : 0231
C2 : 00F2	D2 : 0132	E2 : 0172	F2 : 01B2	G2 : 01F2	H2 : 0232
C3 : 00F3	D3 : 0133	E3 : 0173	F3 : 01B3	G3 : 01F3	H3 : 0233
C4 : 00F4	D4 : 0134	E4 : 0174	F4 : 01B4	G4 : 01F4	H4 : 0234

System Installation

C5 : 00F5	D5 : 0135	E5 : 0175	F5 : 01B5	G5 : 01F5	H5 : 0235
C6 : 00F6	D6 : 0136	E6 : 0176	F6 : 01B6	G6 : 01F6	H6 : 0236
C7 : 00F7	D7 : 0137	E7 : 0177	F7 : 01B7	G7 : 01F7	H7 : 0237
C8 : 00F8	D8 : 0138	E8 : 0178	F8 : 01B8	G8 : 01F8	H8 : 0238
C9 : 00F9	D9 : 0139	E9 : 0179	F9 : 01B9	G9 : 01F9	H9 : 0239
CA : 00C1	DA : 0101	EA : 0141	FA : 0181	GA : 01C1	HA : 0201
CB : 00C2	DB : 0102	EB : 0142	FB : 0182	GB : 01C2	HB : 0202
CC : 00C3	DC : 0103	EC : 0143	FC : 0183	GC : 01C3	HC : 0203
CD : 00C4	DD : 0104	ED : 0144	FD : 0184	GD : 01C4	HD : 0204
CE : 00C5	DE : 0105	EE : 0145	FE : 0185	GE : 01C5	HE : 0205
CF : 00C6	DF : 0106	EF : 0146	FF : 0186	GF : 01C6	HF : 0206
CG : 00C7	DG : 0107	EG : 0147	FG : 0187	GG : 01C7	HG : 0207
CH : 00C8	DH : 0108	EH : 0148	FH : 0188	GH : 01C8	HH : 0208
CI : 00C9	DI : 0109	EI : 0149	FI : 0189	GI : 01C9	HI : 0209
CJ : 00D1	DJ : 0111	EJ : 0151	FJ : 0191	GJ : 01D1	HJ : 0211
CK : 00D2	DK : 0112	EK : 0152	FK : 0192	GK : 01D2	HK : 0212
CL : 00D3	DL : 0113	EL : 0153	FL : 0193	GL : 01D3	HL : 0213
CM : 00D4	DM : 0114	EM : 0154	FM : 0194	GM : 01D4	HM : 0214
CN : 00D5	DN : 0115	EN : 0155	FN : 0195	GN : 01D5	HN : 0215
CO : 00D6	DO : 0116	EO : 0156	FO : 0196	GO : 01D6	HO : 0216
CP : 00D7	DP : 0117	EP : 0157	FP : 0197	GP : 01D7	HP : 0217
CQ : 00D8	DQ : 0118	EQ : 0158	FQ : 0198	GQ : 01D8	HQ : 0218
CR : 00D9	DR : 0119	ER : 0159	FR : 0199	GR : 01D9	HR : 0219
CS : 00E2	DS : 0122	ES : 0162	FS : 01A2	GS : 01E2	HS : 0222
CT : 00E3	DT : 0123	ET : 0163	FT : 01A3	GT : 01E3	HT : 0223
CU : 00E4	DU : 0124	EU : 0164	FU : 01A4	GU : 01E4	HU : 0224
CV : 00E5	DV : 0125	EV : 0165	FV : 01A5	GV : 01E5	HV : 0225
CW : 00E6	DW : 0126	EW : 0166	FW : 01A6	GW : 01E6	HW : 0226
CX : 00E7	DX : 0127	EX : 0167	FX : 01A7	GX : 01E7	HX : 0227

System Installation

CY : 00E8	DY : 0128	EY : 0168	FY : 01A8	GY : 01E8	HY : 0228
CZ : 00E9	DZ : 0129	EZ : 0169	FZ : 01A9	GZ : 01E9	HZ : 0229

Ix	Jx	Kx	Lx	Mx	Nx
I0 : 0270	J0 : 0470	K0 : 04B0	L0 : 04F0	M0 : 0530	N0 : 0570
I1 : 0271	J1 : 0471	K1 : 04B1	L1 : 04F1	M1 : 0531	N1 : 0571
I2 : 0272	J2 : 0472	K2 : 04B2	L2 : 04F2	M2 : 0532	N2 : 0572
I3 : 0273	J3 : 0473	K3 : 04B3	L3 : 04F3	M3 : 0533	N3 : 0573
I4 : 0274	J4 : 0474	K4 : 04B4	L4 : 04F4	M4 : 0534	N4 : 0574
I5 : 0275	J5 : 0475	K5 : 04B5	L5 : 04F5	M5 : 0535	N5 : 0575
I6 : 0276	J6 : 0476	K6 : 04B6	L6 : 04F6	M6 : 0536	N6 : 0576
I7 : 0277	J7 : 0477	K7 : 04B7	L7 : 04F7	M7 : 0537	N7 : 0577
I8 : 0278	J8 : 0478	K8 : 04B8	L8 : 04F8	M8 : 0538	N8 : 0578
I9 : 0279	J9 : 0479	K9 : 04B9	L9 : 04F9	M9 : 0539	N9 : 0579
IA : 0241	JA : 0441	KA : 0481	LA : 04C1	MA : 0501	NA : 0541
IB : 0242	JB : 0442	KB : 0482	LB : 04C2	MB : 0502	NB : 0542
IC : 0243	JC : 0443	KC : 0483	LC : 04C3	MC : 0503	NC : 0543
ID : 0244	JD : 0444	KD : 0484	LD : 04C4	MD : 0504	ND : 0544
IE : 0245	JE : 0445	KE : 0485	LE : 04C5	ME : 0505	NE : 0545
IF : 0246	JF : 0446	KF : 0486	LF : 04C6	MF : 0506	NF : 0546
IG : 0247	JG : 0447	KG : 0487	LG : 04C7	MG : 0507	NG : 0547
IH : 0248	JH : 0448	KH : 0488	LH : 04C8	MH : 0508	NH : 0548
II : 0249	JI : 0449	KI : 0489	LI : 04C9	MI : 0509	NI : 0549
IJ : 0251	JJ : 0451	KJ : 0491	LJ : 04D1	MJ : 0511	NJ : 0551
IK : 0252	JK : 0452	KK : 0492	LK : 04D2	MK : 0512	NK : 0552
IL : 0253	JL : 0453	KL : 0493	LL : 04D3	ML : 0513	NL : 0553
IM : 0254	JM : 0454	KM : 0494	LM : 04D4	MM : 0514	NM : 0554
IN : 0255	JN : 0455	KN : 0495	LN : 04D5	MN : 0515	NN : 0555
IO : 0256	JO : 0456	KO : 0496	LO : 04D6	MO : 0516	NO : 0556

IP : 0257	JP : 0457	KP : 0497	LP : 04D7	MP : 0517	NP : 0557
IQ : 0258	JQ : 0458	KQ : 0498	LQ : 04D8	MQ : 0518	NQ : 0558
IR : 0259	JR : 0459	KR : 0499	LR : 04D9	MR : 0519	NR : 0559
IS : 0262	JS : 0462	KS : 04A2	LS : 04E2	MS : 0522	NS : 0562
IT : 0263	JT : 0463	KT : 04A3	LT : 04E3	MT : 0523	NT : 0563
IU : 0264	JU : 0464	KU : 04A4	LU : 04E4	MU : 0524	NU : 0564
IV : 0265	JV : 0465	KV : 04A5	LV : 04E5	MV : 0525	NV : 0565
IW : 0266	JW : 0466	KW : 04A6	LW : 04E6	MW : 0526	NW : 0566
IX : 0267	JX : 0467	KX : 04A7	LX : 04E7	MX : 0527	NX : 0567
IY : 0268	JY : 0468	KY : 04A8	LY : 04E8	MY : 0528	NY : 0568
IZ : 0269	JZ : 0469	KZ : 04A9	LZ : 04E9	MZ : 0529	NZ : 0569

Ox	Px	Qx	Rx	Sx	Tx
O0 : 05B0	P0 : 05F0	Q0 : 0630	R0 : 0670	S0 : 08B0	T0 : 08F0
O1 : 05B1	P1 : 05F1	Q1 : 0631	R1 : 0671	S1 : 08B1	T1 : 08F1
O2 : 05B2	P2 : 05F2	Q2 : 0632	R2 : 0672	S2 : 08B2	T2 : 08F2
O3 : 05B3	P3 : 05F3	Q3 : 0633	R3 : 0673	S3 : 08B3	T3 : 08F3
O4 : 05B4	P4 : 05F4	Q4 : 0634	R4 : 0674	S4 : 08B4	T4 : 08F4
O5 : 05B5	P5 : 05F5	Q5 : 0635	R5 : 0675	S5 : 08B5	T5 : 08F5
O6 : 05B6	P6 : 05F6	Q6 : 0636	R6 : 0676	S6 : 08B6	T6 : 08F6
O7 : 05B7	P7 : 05F7	Q7 : 0637	R7 : 0677	S7 : 08B7	T7 : 08F7
O8 : 05B8	P8 : 05F8	Q8 : 0638	R8 : 0678	S8 : 08B8	T8 : 08F8
O9 : 05B9	P9 : 05F9	Q9 : 0639	R9 : 0679	S9 : 08B9	T9 : 08F9
OA : 0581	PA : 05C1	QA : 0601	RA : 0641	SA : 0881	TA : 08C1
OB : 0582	PB : 05C2	QB : 0602	RB : 0642	SB : 0882	TB : 08C2
OC : 0583	PC : 05C3	QC : 0603	RC : 0643	SC : 0883	TC : 08C3
OD : 0584	PD : 05C4	QD : 0604	RD : 0644	SD : 0884	TD : 08C4
OE : 0585	PE : 05C5	QE : 0605	RE : 0645	SE : 0885	TE : 08C5
OF : 0586	PF : 05C6	QF : 0606	RF : 0646	SF : 0886	TF : 08C6

System Installation

OG : 0587	PG : 05C7	QG : 0607	RG : 0647	SG : 0887	TG : 08C7
OH : 0588	PH : 05C8	QH : 0608	RH : 0648	SH : 0888	TH : 08C8
OI : 0589	PI : 05C9	QI : 0609	RI : 0649	SI : 0889	TI : 08C9
OJ : 0591	PJ : 05D1	QJ : 0611	RJ : 0651	SJ : 0891	TJ : 08D1
OK : 0592	PK : 05D2	QK : 0612	RK : 0652	SK : 0892	TK : 08D2
OL : 0593	PL : 05D3	QL : 0613	RL : 0653	SL : 0893	TL : 08D3
OM : 0594	PM : 05D4	QM : 0614	RM : 0654	SM : 0894	TM : 08D4
ON : 0595	PN : 05D5	QN : 0615	RN : 0655	SN : 0895	TN : 08D5
OO : 0596	PO : 05D6	QO : 0616	RO : 0656	SO : 0896	TO : 08D6
OP : 0597	PP : 05D7	QP : 0617	RP : 0657	SP : 0897	TP : 08D7
OQ : 0598	PQ : 05D8	QQ : 0618	RQ : 0658	SQ : 0898	TQ : 08D8
OR : 0599	PR : 05D9	QR : 0619	RR : 0659	SR : 0899	TR : 08D9
OS : 05A2	PS : 05E2	QS : 0622	RS : 0662	SS : 08A2	TS : 08E2
OT : 05A3	PT : 05E3	QT : 0623	RT : 0663	ST : 08A3	TT : 08E3
OU : 05A4	PU : 05E4	QU : 0624	RU : 0664	SU : 08A4	TU : 08E4
OV : 05A5	PV : 05E5	QV : 0625	RV : 0665	SV : 08A5	TV : 08E5
OW : 05A6	PW : 05E6	QW : 0626	RW : 0666	SW : 08A6	TW : 08E6
OX : 05A7	PX : 05E7	QX : 0627	RX : 0667	SX : 08A7	TX : 08E7
OY : 05A8	PY : 05E8	QY : 0628	RY : 0668	SY : 08A8	TY : 08E8
OZ : 05A9	PZ : 05E9	QZ : 0629	RZ : 0669	SZ : 08A9	TZ : 08E9

Ux	Vx	Wx	Xx	Yx	Zx
U0 : 0930	V0 : 0970	W0 : 09B0	X0 : 09F0	Y0 : 0A30	Z0 : 0A70
U1 : 0931	V1 : 0971	W1 : 09B1	X1 : 09F1	Y1 : 0A31	Z1 : 0A71
U2 : 0932	V2 : 0972	W2 : 09B2	X2 : 09F2	Y2 : 0A32	Z2 : 0A72
U3 : 0933	V3 : 0973	W3 : 09B3	X3 : 09F3	Y3 : 0A33	Z3 : 0A73
U4 : 0934	V4 : 0974	W4 : 09B4	X4 : 09F4	Y4 : 0A34	Z4 : 0A74
U5 : 0935	V5 : 0975	W5 : 09B5	X5 : 09F5	Y5 : 0A35	Z5 : 0A75
U6 : 0936	V6 : 0976	W6 : 09B6	X6 : 09F6	Y6 : 0A36	Z6 : 0A76
U7 : 0937	V7 : 0977	W7 : 09B7	X7 : 09F7	Y7 : 0A37	Z7 : 0A77
U8 : 0938	V8 : 0978	W8 : 09B8	X8 : 09F8	Y8 : 0A38	Z8 : 0A78
U9 : 0939	V9 : 0979	W9 : 09B9	X9 : 09F9	Y9 : 0A39	Z9 : 0A79
UA : 0901	VA : 0941	WA : 0981	XA : 09C1	YA : 0A01	ZA : 0A41
UB : 0902	VB : 0942	WB : 0982	XB : 09C2	YB : 0A02	ZB : 0A42
UC : 0903	VC : 0943	WC : 0983	XC : 09C3	YC : 0A03	ZC : 0A43
UD : 0904	VD : 0944	WD : 0984	XD : 09C4	YD : 0A04	ZD : 0A44
UE : 0905	VE : 0945	WE : 0985	XE : 09C5	YE : 0A05	ZE : 0A45
UF : 0906	VF : 0946	WF : 0986	XF : 09C6	YF : 0A06	ZF : 0A46
UG : 0907	VG : 0947	WG : 0987	XG : 09C7	YG : 0A07	ZG : 0A47
UH : 0908	VH : 0948	WH : 0988	XH : 09C8	YH : 0A08	ZH : 0A48
UI : 0909	VI : 0949	WI : 0989	XI : 09C9	YI : 0A09	ZI : 0A49
UJ : 0911	VJ : 0951	WJ : 0991	XJ : 09D1	YJ : 0A11	ZJ : 0A51
UK : 0912	VK : 0952	WK : 0992	XK : 09D2	YK : 0A12	ZK : 0A52
UL : 0913	VL : 0953	WL : 0993	XL : 09D3	YL : 0A13	ZL : 0A53
UM : 0914	VM : 0954	WM : 0994	XM : 09D4	YM : 0A14	ZM : 0A54
UN : 0915	VN : 0955	WN : 0995	XN : 09D5	YN : 0A15	ZN : 0A55
UO : 0916	VO : 0956	WO : 0996	XO : 09D6	YO : 0A16	ZO : 0A56
UP : 0917	VP : 0957	WP : 0997	XP : 09D7	YP : 0A17	ZP : 0A57
UQ : 0918	VQ : 0958	WQ : 0998	XQ : 09D8	YQ : 0A18	ZQ : 0A58

UR : 0919	VR : 0959	WR : 0999	XR : 09D9	YR : 0A19	ZR : 0A59
US : 0922	VS : 0962	WS : 09A2	XS : 09E2	YS : 0A22	ZS : 0A62
UT : 0923	VT : 0963	WT : 09A3	XT : 09E3	YT : 0A23	ZT : 0A63
UU : 0924	VU : 0964	WU : 09A4	XU : 09E4	YU : 0A24	ZU : 0A64
UV : 0925	VV : 0965	WV : 09A5	XV : 09E5	YV : 0A25	ZV : 0A65
UW : 0926	VW : 0966	WW : 09A6	XW : 09E6	YW : 0A26	ZW : 0A66
UX : 0927	VX : 0967	WX : 09A7	XX : 09E7	YX : 0A27	ZX : 0A67
UY : 0928	VY : 0968	WY : 09A8	XY : 09E8	YY : 0A28	ZY : 0A68
UZ : 0929	VZ : 0969	WZ : 09A9	XZ : 09E9	YZ : 0A29	ZZ : 0A69

8 Related publications

You will find the manuals on the internet at <http://manuals.ts.fujitsu.com>. You can order printed versions of manuals which are displayed with the order number.

- [1] **BS2000 OS DX
Utility Routines**
User Guide
- [2] **BS2000 OS DX
Commands**
User Guides
- [3] **BS2000 OS DX
Performance Handbook**
User Guide
- [4] **BS2000 OS DX
Introduction to System Administration**
User Guide
- [5] **SE series
Operation and Administration**
User Guide
- [6] **DRV
Dual Recording by Volume**
User Guide
- [7] **HIPLEX MSCF
BS2000-Processor Networks**
User Guide
- [8] **HSMS (BS2000)
Hierarchical Storage Management System**
User Guide
- [9] **JV
Job Variables**
User Guide
- [10] **MAREN
Tape management in BS2000**
User Guide
- [11] **openNet Server
BCAM**
User Guide
- [12] **SHC-OSD
Storage Management for BS2000**
User Guide

VM2000

[13] **Virtual Machine System**
User Guide