

English



Fujitsu Server BS2000 SE Series

# Server Unit x86

Operating Manual

---

Valid for:  
M2000 V6.5A  
X2000 V6.5A  
HNC V6.5A

Edition December 2023

## Comments... Suggestions... Corrections...

The User Documentation Department would like to know your opinion on this manual. Your feedback helps us to optimize our documentation to suit your individual needs.

Feel free to send us your comments by e-mail to: [bs2000services@fujitsu.com](mailto:bs2000services@fujitsu.com).

## Certified documentation according to DIN EN ISO 9001:2015

To ensure a consistently high quality standard and user-friendliness, this documentation was created to meet the regulations of a quality management system which complies with the requirements of the standard DIN EN ISO 9001:2015.

## Copyright and Trademarks

Copyright © 2023 Fujitsu Technology Solutions GmbH.

All rights reserved.

Delivery subject to availability; right of technical modifications reserved.

All hardware and software names used are trademarks of their respective manufacturers.

The Xen® mark is a trademark of Citrix Systems, Inc., which manages the mark on behalf of the Xen open source community. The Xen® mark is registered with the U.S. Patent and Trademark Office, and may also be registered in other countries.

Novell and SUSE are registered brands of Novell, Inc. in the USA and other countries.

Linux is a registered brand of Linus Torvalds.

Windows® is a registered trademark of Microsoft Corporation.

The Linux-based basic software M2000, X2000, and HNC which is installed on the Management Unit, Server Unit x86, and HNC contains Open Source Software. The licenses for this can be found in the LICENSES directory on the relevant installation DVD.

# Table of Contents

- Server Unit x86 ..... 4**
- 1 Introduction ..... 5**
- 2 Server Unit SU x86 ..... 6**
  - 2.1 Switching the Server Unit on/off ..... 7**
  - 2.2 Front of the Server Unit ..... 8**
    - 2.2.1 Controls ..... 11
    - 2.2.2 Indicators on the operating panel ..... 12
    - 2.2.3 Hard disks ..... 14
    - 2.2.4 DVD-RW drive ..... 15
  - 2.3 Rear of the Server Unit ..... 16**
- 3 What to do if ... ..... 20**
- 4 Related publications ..... 21**

---

# Server Unit x86

---

# 1 Introduction

The Fujitsu Server BS2000 SE series with its innovative HW and SW features forms the proven mainframe line from Fujitsu. Designed as hybrid systems, the SE servers create a new quality of openness and integration capability of different server and peripheral systems with simultaneous comprehensive and cross-system manageability.

Under the umbrella of the SE infrastructure, multiple application scenarios are possible in various combinations for both mainframe applications and applications of the open world. The server architecture offers comprehensive performance scalability (scale-up and scale-out), and ensures that users can manage their application workloads securely, quickly and efficiently across technological boundaries with maximum availability.

One major aim of the SE servers is to provide a uniform management strategy which offers customers significant added value through maximum integration, and guarantees extremely cost-effective operation of their IT. The heart of the SE series is formed by the /390-based Server Units, the x86-based Server Units, the Net Unit (NU) and the Management Unit (MU).

All components are integrated into a standard 19" rack and are supplied to customers ready to use.

In addition to their high system performance, the servers of the SE series offer enhanced configuration options, maximum availability and, not least of all, significantly reduced power consumption compared with predecessors.

Depending on requirements, the SE server contains all the system components needed for operation as an overall application:

- Server Unit /390 for BS2000 guest systems
- Server Unit x86 for BS2000 guest systems
- Application Units x86 for operating Native or hypervisor systems (e.g. Linux, Windows, VMware, etc.)
- Net Unit as a high-speed, server-internal infrastructure to connect the components with each other and with the customer's IP networks.
- Shareable tape and disk periphery
- Infrastructure to connect the components with the customer's FC networks

## Information on using the manual

The Operating Manual consists of a number of modules and describes the features and hardware components of the Fujitsu Server BS2000 SE series. Users should read the operating manuals carefully in order to obtain optimal performance from the SE server.

This manual describes the hardware component Server Unit x86 and complements the Basic Operating Manual [1]. You will find a comprehensive introductory chapter in the Basic Operating Manual. The chapters "Important notes" on SE server operation and "Environmental protection and service" are contained only in the Basic Operating Manual.

In the following, abbreviations are used to describe the SE server models and their components. These are explained in the introduction to the Basic Operating Manual [1] in the section "Models, Names, Abbreviations".

---

## 2 Server Unit SU x86

This section describes the Server Units SU310 in an SE server SE310, SU320 in an SE server SE320 and SU330 / SU330B in an SE server SE330 / SE330B. SU330 / SU330B can optionally also be present in an SE730 / SE730B.

**i** Components and ports which are not used are not described below.

In the SU x86 the base system X2000 enables BS2000 to execute (in Native mode or on BS2000 VMs).

An SU310 occupies two height units (HUs) in the rack, an SU320 as well as an SU330 / SU330B occupies three HUs.

### Features

- For SU310 there are three models with four processors (16 cores) each, for SU320 one model with also four processors. Capacity on Demand permits temporary processor attachment. For SU330 / SU330B 11 models are available with up to 16 BS2000 processors.
- The size of the main memory (for BS2000 and for the base system X2000) is 128 GB in the basic configuration. These models can be enhanced to up to 512 GB.
- For the input/output system the Server Unit contains two 2.5" SAS hard disks with a capacity of 600 GB each (on SU310 and SU320) resp. two SATA SSDs with a capacity of 960 GB each (on SU330 / SU330B) in the basic configuration, which are mirrored.
- The Server Unit contains a DVD-RW drive.
- Fibre Channels operating at 16 or 32 Gbps are available for connecting peripherals.
- The Server Unit is connected to the Net Unit via two ports of a LAN controller with 1 Gbit/s included in the basic configuration. With optionally available 1/10 Gbit/s LAN controllers, it is also possible to connect a 10 Gbit/s Net Unit extension or connect directly to the customer infrastructure.
- Each SU x86 is equipped with two power supply units.

---

## 2.1 Switching the Server Unit on/off

Information on switching on and starting the SE server and on switching it off and shutting it down is provided in the "Basic Operating Manual" [1], section "Switching the server on and off".

### Switching the Server Unit on

Before the Server Unit is switched on, the power status indicator lights up green (item 5 in [figure 2](#)) resp. on SU320 and SU330 / SU330B the status indicator (item 1 in [figure 4](#)) lights up white.

- > As administrator, BS2000 administrator or authorized BS2000 operator, switch on the Server Unit using the SE Manager (menu *Hardware* -> *Units*, *Units* tab, *Power on* icon for the Server Unit), see the "Operation and Administration" manual [5].

The On/Off switch / status indicator lights up green (item 4 in [figure 2](#) resp. item 1 in [figure 4](#)). The Server Unit switches on, conducts a system test and starts X2000.

If automatic IPL is configured for BS2000, the BS2000 system (Native or as a VM2000 monitor system) is also started with the configured settings.

### Switching the Server Unit off

Before the Server Unit is switched off, the On/Off switch / status indicator lights up green, and after the Server Unit has been switched off it no longer lights up resp. on SU320 and SU330 / SU330B lights up white (item 4 in [figure 2](#) resp. item 1 in [figure 4](#)).

- > As administrator, BS2000 administrator or authorized BS2000 operator, switch off the Server Unit using the SE Manager (menu *Hardware* -> *Units*, *Units* tab, *Power off* icon for the Server Unit), see the "Operation and Administration" manual [5].

When the Server Unit is switched off, the BS2000 system is shut down properly taking into account the remaining runtime specified.

The power status indicator (item 5 in [figure 2](#), only on SU310) lights up green when the server is switched off but connected to the power supply (power cable connected).

This status indicator does not light up in the following situations:

- The Server Unit is switched off and not connected to the power source.
- The Server Unit is switched on and operating normally.

On SU320 and SU330 / SU330B the power status indicator is integrated into the On/Off switch / status indicator. The On/Off switch / status indicator lights up white when the Server Unit is switched off, but connected to the power supply (power cable connected).

The On/Off switch / status indicator does not light up when the SU320 is switched off and not connected to the power supply. It lights up green when the Server Unit is switched on and is in normal operation mode.

## 2.2 Front of the Server Unit

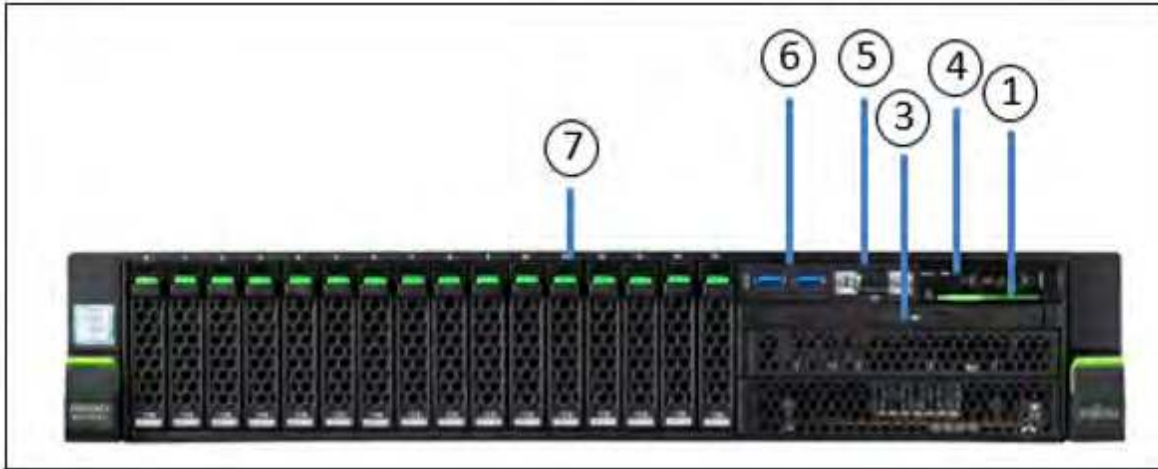

Figure 1: Server Unit SU310 (front)

No.	Meaning
1	ID card (green)
3	Optical drive activity indicator
4	Operating panel (for details see figure 2)
5	Video port (for Customer Support only)
6	USB ports (2x, for Customer Support only)
7	HDD indicators

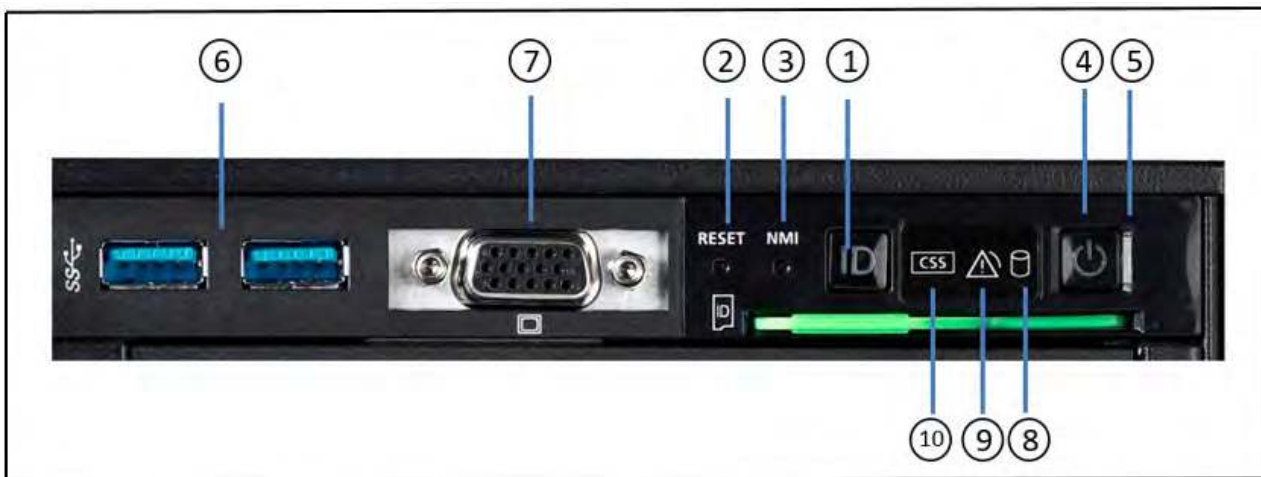

Figure 2: SU310 front - Detailed view: Operating panel

No.	Meaning
1	ID button/ ID indicator
2	Reset button
3	NMI button
4	On/Off button / Status indicator
5	Status indicator (power cable connected)
6	2x USB ports (for Customer Support only)
7	Video port (for Customer Support only)
8	HDD activity indicator
9	Global error indicator
10	CSS indicator

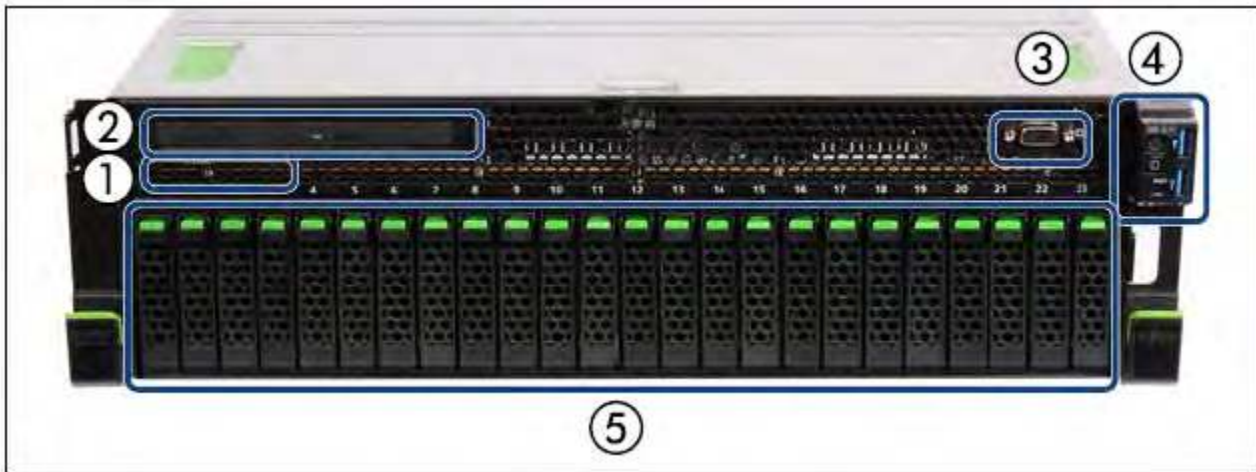

Figure 3: Server Unit SU320/SU330/SU330B (front)

No.	Meaning
1	ID card
2	Optical disk drive (optional)
3	Video port (for Customer Support only)
4	Operating panel (for details see figure 4)
5	2.5-inch HDDs/SSDs/PCIe-SSDs (8x, 16x or 24x)

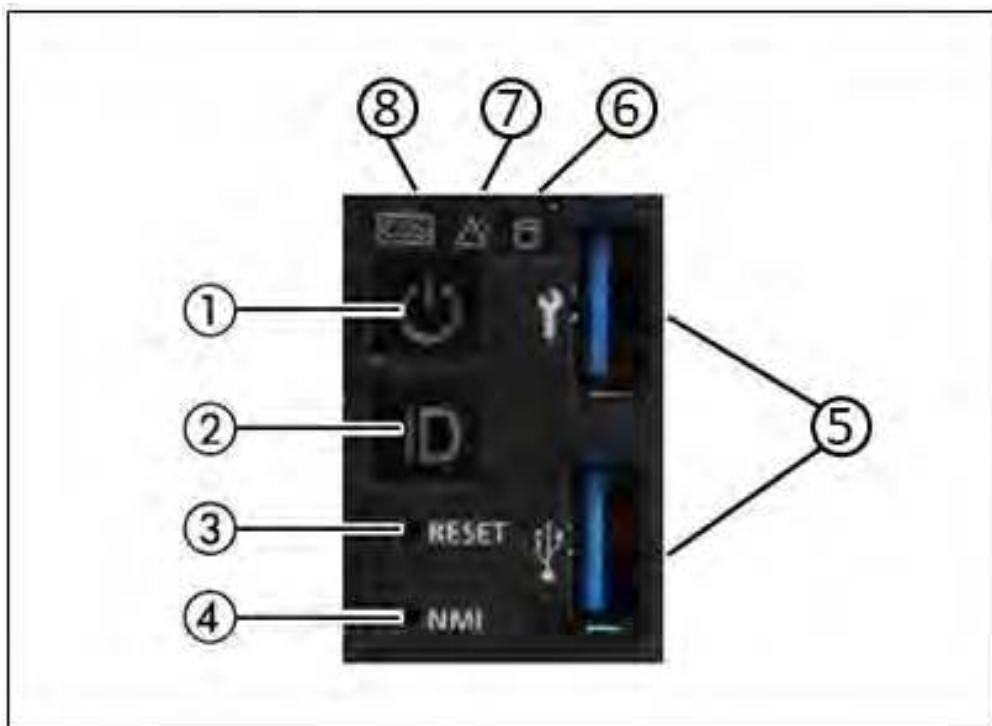

Figure 4: SU320/SU330/SU330B front - Detailed view: Operating panel

No.	Meaning
1	On/off switch / status indicator
2	ID button
3	Reset button
4	NMI button
5	2x USB 3.0 port
6	HDD/SSD activity indicator
7	Global error indicator
8	CSS indicator

## ID card

You can pull the ID card (see [figure 1/3](#)) out and push it in again as far as it will go.



The ID card contains various system information, e.g. product name, serial number, MAC addresses and DNS name.

## 2.2.1 Controls

Control	Meaning
<b>ID</b>	<p>Identification (ID) button</p> <p>The ID indicators light up (blue) on the front and on the rear of the Server Unit when the ID button is pressed. The two ID indicators are synchronized.</p>
	<p>On/Off switch</p> <p>When the Server Unit is switched off, it is switched on again by pressing the On/Off switch once.</p> <p>When the Server Unit is in operation, it is switched off by pressing the On/Off switch once (this takes a little time).</p> <p>Normally the system may only be switched on or off by Customer Support. The customer should only perform an “emergency power off”, see SE x86 "Switching off in an emergency" in the Basic Operating Manual [1].</p> <p>For information on switching on and starting the SE300 and on switching it off and shutting it down, see "Switching the SE x86 on and off" in the Basic Operating Manual [1].</p> <div data-bbox="266 873 1455 1062" style="background-color: #fff9c4; padding: 10px;"> <p><b>! CAUTION!</b>  <b>Loss of data</b>            When the On/Off switch is pressed and held down for several seconds, Server Unit operation is terminated ungracefully and abruptly. Notify Customer Support.</p> </div> <div data-bbox="266 1092 1455 1201" style="background-color: #e1f5fe; padding: 10px;"> <p><b>i</b> The On/Off switch does not disconnect the server from the voltage grid. To disconnect from the voltage grid completely, remove the power plug(s).</p> </div>
<b>RESET</b>	<p>Reset button</p> <p>Pressing the Reset button reboots the Server Unit.</p> <div data-bbox="266 1373 1455 1482" style="background-color: #fff9c4; padding: 10px;"> <p><b>! CAUTION!</b>            Possible loss of data!</p> </div>
<b>NMI</b>	<p>NMI button</p> <div data-bbox="266 1600 1455 1709" style="background-color: #fff9c4; padding: 10px;"> <p><b>! CAUTION!</b>            Do not press! Possible loss of data! The NMI button may only be used by Customer Support.</p> </div>

## 2.2.2 Indicators on the operating panel

Indicator	Meaning
<p><b>ID</b></p>	<p><b>ID indicator (blue)</b></p> <p>Lights up blue when the Server Unit has been selected by pressing the ID button. To deactivate, press the button again.</p> <p>The ID indicator can also be activated via the ServerView Operations Manager and the iRMC web interface, and its status can be reported to the ServerView Operations Manager and the iRMC.</p>
<p></p>	<p><b>On SU310:</b></p> <p>Beside the status indicator there is a separate power status indicator.</p> <p><b>Status indicator (green)</b></p> <p><b>Does not light up</b> when the Server Unit is switched off but connected to the power supply (power cable connected).</p> <p><b>Lights up green</b> during power up and when operating normally (S0).</p> <p><b>Power status indicator (power cable connected) (green)</b> on the right-hand side of the On/Off switch</p> <p><b>Does not light up</b> in the following cases:</p> <ul style="list-style-type: none"> <li>• The Server Unit is not connected to the power source.</li> <li>• The Server Unit is switched on and operating normally (S0).</li> </ul> <p><b>Lights up green</b> when one of the following cases occurs:</p> <ul style="list-style-type: none"> <li>• The Server Unit is switched off but connected to the power supply (power cable connected).</li> <li>• The Server Unit is switched on but is in the power up delay.</li> </ul> <p><b>On SU320 and SU330 / SU330B:</b></p> <p>The power status indicator is integrated into the status indicator.</p> <p><b>Status indicator (green and white)</b></p> <p><b>Does not light up</b> when the Server Unit is not connected to the power source.</p> <p><b>Lights up white</b> when the Server Unit is switched off but connected to the power supply (power cable connected).</p> <p><b>Alternate flashing green and white</b> when the Server Unit is switched on but is in the power up delay.</p> <p><b>Lights up green</b> when the Server Unit is switched on and operating normally (S0).</p> <div style="background-color: #e6f2ff; padding: 10px; border: 1px solid #add8e6;"> <p><b>i</b> After the Server Unit has been connected to the power source, it takes approximately 60 seconds until the Server Unit has entered standby mode.</p> </div>

	<p><b>HDD activity indicator (green)</b></p> <p><b>Lights up green</b> when an internal hard disk drive is being accessed.</p>
	<p><b>Global error indicator (yellow)</b></p> <p><b>Lights up yellow</b> when a prefailure event was detected which requires Customer Support to become active (by way of precaution).</p> <p><b>Flashes yellow</b> when an error was detected which requires Customer Support to become active.</p> <p><b>Does not light up</b> when no critical event has occurred.</p> <p>If the event is still acute after a power failure, the indicator is activated after the restart.</p> <p>The indicator also lights up in standby mode.</p> <p>If the indicator flashes or lights up <b>yellow</b>, call Customer Support.</p>
<p><b>CSS</b></p>	<p><b>CSS indicator (yellow)</b></p> <p><b>Lights up yellow</b> when a prefailure event was detected which requires Customer Support to become active (by way of precaution).</p> <p><b>Flashes yellow</b> when an error was detected which requires Customer Support to become active.</p> <p><b>Does not light up</b> when no critical event has occurred.</p> <p>If the event is still acute after the Server Unit has been switched on/off, the indicator is activated after the restart.</p> <p>The indicator also lights up in standby mode.</p> <p>If the indicator flashes or lights up <b>yellow</b>, call Customer Support.</p>

## 2.2.3 Hard disks

The following description for hard disks (HDDs) also applies to the SSDs available in newer units.



Figure 7: Indicators on a hot-plug HDD module

No.	Meaning
1	HDD BUSY (green) <ul style="list-style-type: none"><li>• Lights up: HDD in active phase (drive active, access to drive)</li><li>• Does not light up: HDD inactive</li></ul>
2	HDD FAULT (orange) <ul style="list-style-type: none"><li>• Does not light up: No HDD error</li><li>• Lights up: HDD Faulty or Rebuild Stopped (drive defective / needs replacing, a rebuild process was stopped or the slide-in module is not correctly inserted)</li><li>• Slow flashing: HDD Rebuild</li><li>• (the data is being restored after changing a hard disk drive)</li></ul>

If a hard disk drive continuously indicates an error, the drive should be replaced by Customer Support as soon as possible. In this case call Customer Support.

## 2.2.4 DVD-RW drive

The DVD-RW drive enables you to read digital data which is stored on a data CD or data DVD (CD-R or DVD-R for example).

You can also store digital data on a writeable CD or DVD.

This drive is used for:

- X2000: providing an update (administrator or Customer Support)
- BS2000: installing a BS2000 emergency system (administrator or Customer Support)
- BS2000: updating BS2000 via EMFILE (administrator)
- BS2000: data transfer between BS2000 systems via EMFILE (customer/administrator)
- BS2000: creating a BS2000 EMFILE on CD/DVD directly from the BS2000 system (customer/administrator)

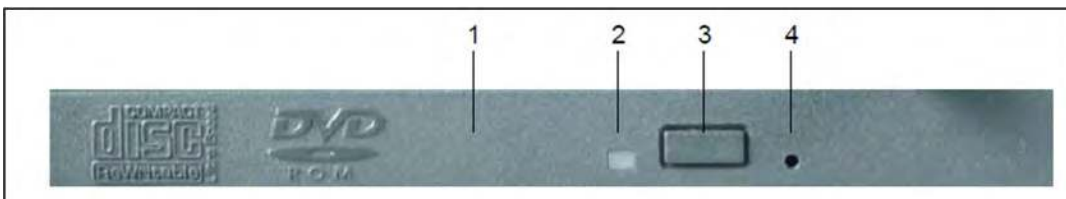

Figure 8: DVD-RW drive: front view

No.	Meaning
1	Drive tray: contains the CD/DVD
2	Drive indicator: <ul style="list-style-type: none"><li>• flashes quickly when a CD/DVD is inserted</li><li>• goes out when the drive is ready for reading</li><li>• lights up when the DVD drive is accessed</li></ul>
3	Eject button: To open the tray press the button briefly (for less than 1 second)
4	Opening for manually removing the CD/DVD (Customer Support)

### i

- After the CD/DVD has been inserted, the medium/drive must still be assigned for BS2000 operation by using BS2000 commands (`/ATTACH-DEVICE` or `/CHECK-TAPE`) (see the “Operation and Administration” manual [5]).
- The device must be detached in BS2000 to permit it to be used in X2000 or for installation of the BS2000 emergency system.
- When the drive indicator has gone out, the CD/DVD can then be ejected using `/UNLOAD-TAPE` (if the device is still attached in the BS2000 system) or by briefly pressing the eject button.

## 2.3 Rear of the Server Unit

### Rear of the SU310

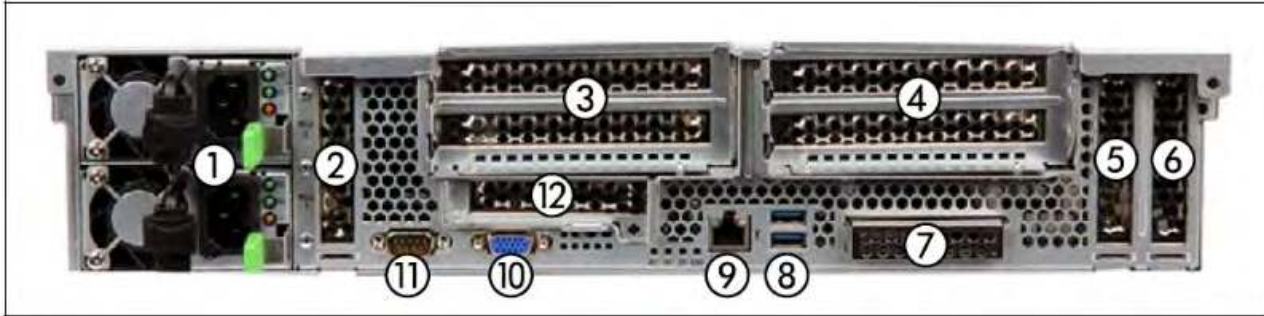

Figure 13: SU310 (rear)

No.	Meaning
1	Power cord connections
2	PCI slot 8 (low profile)
3	PCI slot 7 (top), PCI slot 6 (bottom)
4	PCI slot 4 (top), PCI slot 3 (bottom)
5	PCI slot 2 (low profile)
6	PCI slot 1 (low profile)
7	Onboard LAN (SYS1/SYS2 connections)
8	2x USB 3.0 ports
9	iRMC Management LAN (SYS0)
10	VGA connection (to KVM adapter)
11	Serial connection (normally unused)
12	PCI slot 5 (low profile)



Figure 14: Principle of PCIe slot assignment at the rear of the device (SU310)

## Rear of the SU320 / SU330

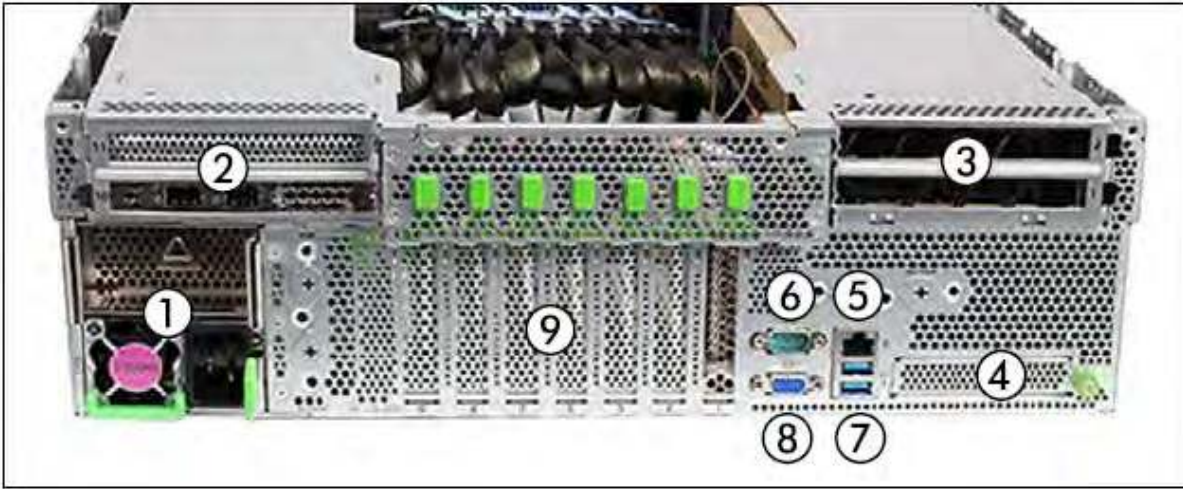

Figure 15: SU320/SU330 (rear)

No.	Meaning
1	Power cord connections (one or two)
2	PCIe slots 10 and 11 (riser module)
3	PCIe slots 1 and 2 (riser module)
4	OCP module (optional)
5	Management LAN
6	Serial connection
7	2x USB 3.0 ports
8	VGA connection (to KVM adapter)
9	PCIe slots 3 - 9 (low profile)

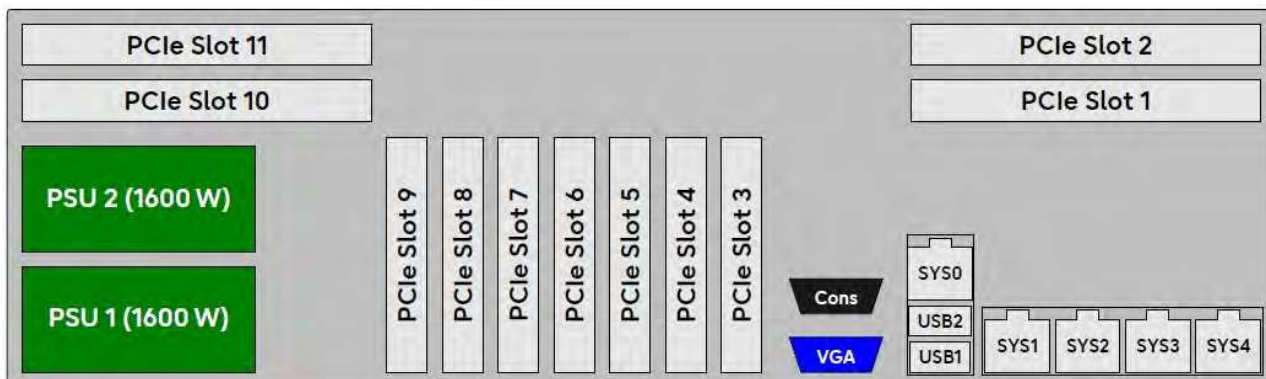

Figure 16: Principle of PCIe slot assignment at the rear of the device (SU320/SU330)

## Rear of the SU330B

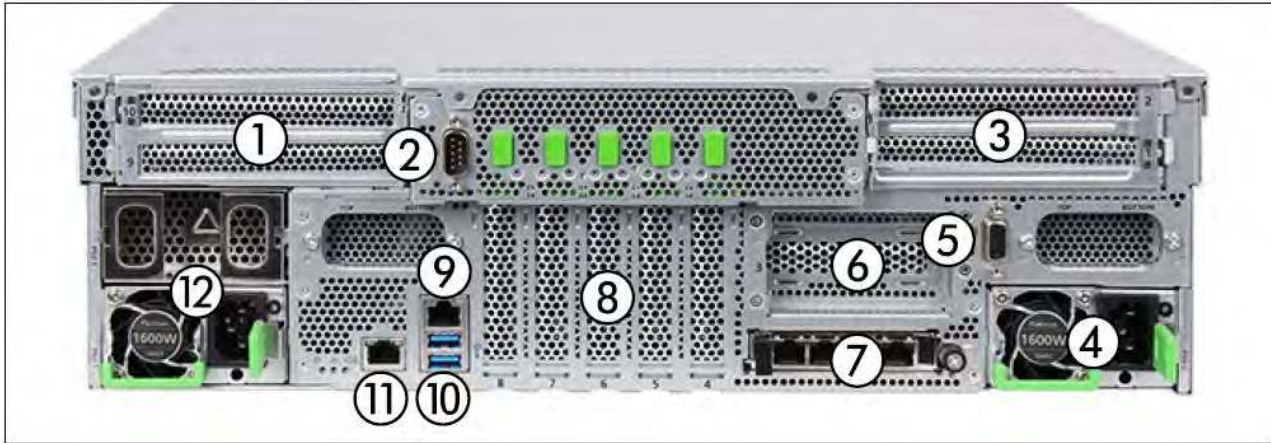

Figure 17: SU330B (rear)

No.	Meaning
1	PCIe slots 9 and 10 (riser module)
2	Serial connection
3	PCIe slots 1 and 2 (riser module)
4	Power cord connection
5	VGA connection (to KVM adapter)
6	PCIe slot 3 (LP riser module, optional)
7	OCP module (optional)
8	PCIe slots 4 - 8
9	Shared LAN
10	2x USB 3.1 ports
11	Management LAN
12	Power cord connections (up to two)

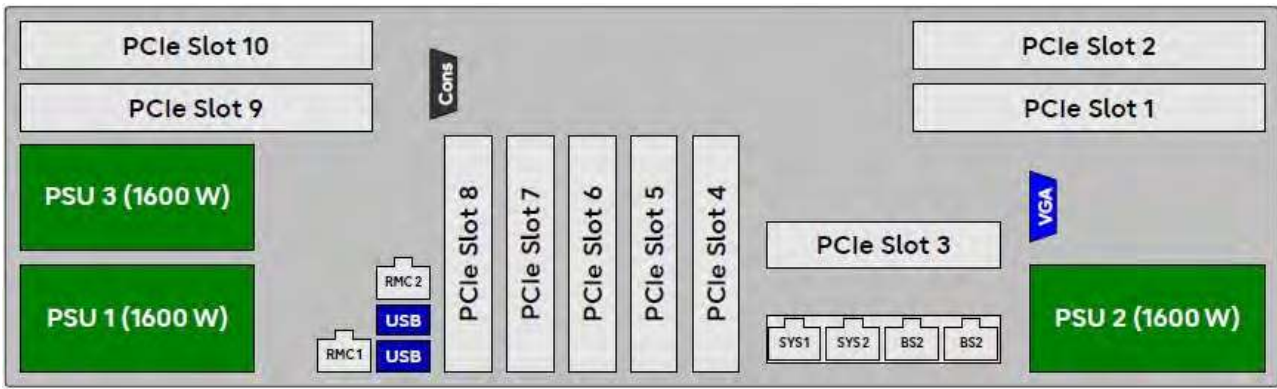

Figure 18: Principle of PCIe slot assignment at the rear of the device (SU330B)

---

## 3 What to do if ...

In this chapter, you will learn how to perform a system dump and create diagnostic documentation for the base system X2000 when inexplicable system downtime occurs.

In the event of hardware faults the operating system will take the necessary recovery action autonomously. Customer Service is automatically informed by means of a Service Call and initiates repair measures, possibly in conjunction with the customer.

The SE Manager displays information on the hardware status of the Server Unit in the menu *Hardware* -> *Units*, *Units* tab.

### Performing a system dump

#### Requirement

Logging into the SE Manager as administrator or authorized BS2000 operator.

1. In the menu *Systems* -> [*<se server> (SE<model>)* ->] *<su-name> (SU3xx)* -> *BS2000* select the *Operation* tab (in VM2000 mode the tab must be selected on the monitor VM).
2. Perform the *BS2000 Dump IPL* action.

The memory dump stored by the DUMP program to disk or tape is required for error diagnosis.

The BS2000/VM2000 system must subsequently be reloaded by means of IPL.

**i** Information on SLED operation is provided in the "Introduction to System Administration" manual [8].

### Creating diagnostic documentation

#### Requirement

Logging into the SE Manager as administrator or authorized BS2000 operator.

1. In the menu *Service* -> *Units* -> [*<se server> (SE<model>)* ->] *<su-name> (SU3xx)* select the *Diagnostics* tab.
2. Perform the *Create new diagnostic data* action.

The created diagnostic data file is a compressed tar archive and contains important logging, trace, and configuration files of the unit. You can download the diagnostic data file and send it to the Support Center for assessment.

---

## 4 Related publications

You can find the following BS2000 manuals on the manual server with the BS2000 documentation at <https://bs2manuals.ts.fujitsu.com>.

Other manuals, for example descriptions of the Fujitsu PRIMERGY and PRIMEQUEST servers, can be found on the general Fujitsu manual server at <https://support.ts.fujitsu.com/>.

- [1] **Fujitsu Server BS2000 SE Series  
Basic Operating Manual**
- [2] **Fujitsu Server BS2000 SE Series  
Server Unit /390  
Operating Manual**
- [3] **Fujitsu Server BS2000 SE Series  
Server Unit x86  
Operating Manual**
- [4] **Fujitsu Server BS2000 SE Series  
Additive Components  
Operating Manual**
- [5] **Fujitsu Server BS2000 SE Series  
Operation and Administration  
User Guide**
- [6] **Fujitsu Server BS2000 SE Series  
Security Manual  
User Guide**
- [7] **Fujitsu Server BS2000 SE Series  
Quick Guide  
User Guide**
- [8] **BS2000 OSD DX  
Introduction to System Administration  
User Guide**