

English



Fujitsu Server BS2000 SE Series

Server Unit /390

Operating Manual

Valid for:
M2000 V6.6A
X2000 V6.6A
HNC V6.6A

Edition November 2024

Comments... Suggestions... Corrections...

The User Documentation Department would like to know your opinion on this manual. Your feedback helps us to optimize our documentation to suit your individual needs.

Feel free to send us your comments by e-mail to: bs2000.info@fujitsu.com.

Certified documentation according to DIN EN ISO 9001:2015

To ensure a consistently high quality standard and user-friendliness, this documentation was created to meet the regulations of a quality management system which complies with the requirements of the standard DIN EN ISO 9001:2015.

Copyright and Trademarks

Copyright © 2026 Fujitsu

All rights reserved.

Delivery subject to availability; right of technical modifications reserved.

All hardware and software names used are trademarks of their respective manufacturers.

The Xen® mark is a trademark of Citrix Systems, Inc., which manages the mark on behalf of the Xen open source community. The Xen® mark is registered with the U.S. Patent and Trademark Office, and may also be registered in other countries.

Novell and SUSE are registered brands of Novell, Inc. in the USA and other countries.

Linux is a registered brand of Linus Torvalds.

Windows® is a registered trademark of Microsoft Corporation.

The Linux-based basic software M2000, X2000, and HNC which is installed on the Management Unit, Server Unit x86, and HNC contains Open Source Software. The licenses for this can be found in the LICENSES directory on the relevant installation DVD.

Table of Contents

- Server Unit /390** **5**
- 1 Introduction** **6**
- 2 Server Unit SU710 / SU730 / SU730B / SU740** **7**
- 3 Operating the service processor** **9**
 - 3.1 Opening the SVP console** **10**
 - 3.2 General SVP frame structure** **12**
 - 3.2.1 System status messages in line 22 13
 - 3.2.2 System status messages in line 23 14
 - 3.2.3 Hardware status display in line 24 15
 - 3.2.4 Status displays in line 25 16
 - 3.3 Using SVP frames** **18**
 - 3.3.1 SVP functions (function keys) 19
 - 3.3.2 Switching between SVP frames 22
 - 3.3.3 Options for switching between frames 23
 - 3.4 SVP frames and subframes** **24**
 - 3.4.1 (ML) MODE SELECTION FRAME 25
 - 3.4.2 (LD) PROGRAM LOAD FRAME: BASIC 28
 - 3.4.2.1 (LD) PROGRAM LOAD FRAME: DETAIL-1 30
 - 3.4.2.2 (LD) PROGRAM LOAD FRAME: DETAIL-2 33
 - 3.4.3 (ST) STATUS DISPLAY FRAME 35
 - 3.4.4 (MA) MANUAL OPERATION FRAME 36
 - 3.4.5 (AD) ALTER/DISPLAY FRAME 39
 - 3.4.6 (ME) MESSAGE FRAME 42
 - 3.4.7 (CH) CH/SUBCH STATUS DISPLAY FRAME: CHANNEL 43
 - 3.4.8 (AU) AUXILIARY FRAME: MENU 45
 - 3.4.8.1 (AU1) AUXILIARY FRAME: REAL CLOCK 46
 - 3.4.8.2 (AU2) AUXILIARY FRAME: IORSF CONTROL 47
 - 3.4.8.3 (AU3) AUXILIARY FRAME: RELATED SCB'S 49
 - 3.4.8.4 (AU4) AUXILIARY FRAME: POWER STAND-BY/IMPL 50
 - 3.4.8.5 (AU5) AUXILIARY FRAME: LOAD PRESET1 51
 - 3.4.9 (MF) MSF FRAME 54
 - 3.4.10 (PA) PERFORMANCE ANALYZER FRAME 55
 - 3.5 Examples of SVP operation** **56**
 - 3.5.1 Selecting IORSF 57
 - 3.5.2 Activating IORSF 60
 - 3.5.3 Setting up PROGRAM LOAD FRAME PRESET1 61
 - 3.5.4 Setting up PROGRAM LOAD FRAME PRESET2 63

3.5.5 Executing IPL in PROGRAM LOAD FRAME: DETAIL-1	65
3.5.6 Setting operating mode via PROGRAM LOAD FRAME: DETAIL-2	69
4 HNC (High-speed Net Connect)	71
4.1 Front of the HNC	72
4.1.1 Controls	75
4.2 Rear of the HNC	78
5 What to do if	83
6 Related publications	85

Server Unit /390

1 Introduction

The Fujitsu Server BS2000 SE series with its innovative HW and SW features forms the proven mainframe line from Fujitsu. Designed as hybrid systems, the SE servers create a new quality of openness and integration capability of different server and peripheral systems with simultaneous comprehensive and cross-system manageability.

Under the umbrella of the SE infrastructure, multiple application scenarios are possible in various combinations for both mainframe applications and applications of the open world. The server architecture offers comprehensive performance scalability (scale-up and scale-out), and ensures that users can manage their application workloads securely, quickly and efficiently across technological boundaries with maximum availability.

One major aim of the SE servers is to provide a uniform management strategy which offers customers significant added value through maximum integration, and guarantees extremely cost-effective operation of their IT. The heart of the SE series is formed by the /390-based Server Units, the x86-based Server Units, the Net Unit (NU) and the Management Unit (MU).

All components are integrated into a standard 19 rack and are supplied to customers ready to use.

In addition to their high system performance, the servers of the SE series offer enhanced configuration options, maximum availability and, not least of all, significantly reduced power consumption compared with predecessors.

Depending on requirements, the SE server contains all the system components needed for operation as an overall application:

- Server Unit /390 for BS2000 guest systems
- Server Unit x86 for BS2000 guest systems
- Application Units x86 for operating Native or hypervisor systems (e.g. Linux, Windows, VMware, etc.)
- Net Unit as a high-speed, server-internal infrastructure to connect the components with each other and with the customer's IP networks
- Shareable tape and disk periphery
- Infrastructure to connect the components with the customer's FC networks

Information on using the manual

The Operating Manual consists of a number of modules and describes the features and hardware components of the Fujitsu Server BS2000 SE series. Users should read the operating manuals carefully in order to obtain optimal performance from the SE server.

This manual describes the hardware component Server Unit /390 (SU710 resp. SU730 / SU730B) and complements the Basic Operating Manual [1]. You will find a comprehensive introductory chapter in the Basic Operating Manual. The chapters "Important notes" on SE server operation and "Environmental protection and service" are contained only in the Basic Operating Manual.

In the following, abbreviations are used to describe the SE server models and their components. These are explained in the introduction to the Basic Operating Manual [1] in the section "Models, Names, Abbreviations".

2 Server Unit SU710 / SU730 / SU730B / SU740

This section describes the Server Units SU710, SU730 / SU730B and SU740. The SE server SE710 contains an SU710, the SE server SE730 / SE730B is equipped with an SU730 / SU730B as the first Server Unit and the SE740 with an SU740.

i Components and ports which are not used are not described below.

The SU710 / SU730 / SU730B / SU740 enables BS2000 to execute on /390 architecture (in Native mode or as BS2000 guest systems).

Features

- Several models with a high performance range are available. Depending on the model, one or two processor modules are used. The processor module has 8 CPUs. Depending on the model, 1 to 16 processors are available. Capacity on Demand permits temporary processor attachment.
- One hot spare processor is available with dynamic activation.
- The main memory is up to 256GB in size for SU710, SU730 and SU730B and up to 128GB in size for SU740.
- The I/O system has up to 126 Fibre Channels, each with a throughput of 16Gbit/s or 64Gbit/s (on SU740) respectively.
- The SU supports a 1Gbit/s, 10Gbit/s or 25Gbit/s (for SE740) LAN (connection via the HNC).

The Server Unit SU710 / SU730 / SU730B / SU740 consists of the following components:

- a CPU box
- an AROMA-P (Automatic and Remote Operation Manager) controls the power supply of the SU and occupies two height units (HUs).
- two to eight channel boxes

CPU box

Depending on the configuration, the CPU box contains one or two (SE710, SE730, SE730B only) system boards.

Each system board contains a processor chip with the following features:

- depending on the model, up to 16 CPU cores with a joint cache
- four IOPs (I/O processors)
- one MAC (Memory Access Controller)
- The processor chip is connected directly to the memory of the system board.

The CPU box, together with AROMA-P, occupies six height units in the rack.

Channel box (CHE box)

Depending on the configuration level, at least two and up to eight channel boxes and up to 126 FC channels are possible in an SU /390. In the basic configuration, the SU /390 has two channel boxes, channel box #0 and channel box #4.

Up to eight channel modules, each with two FC channels (16Gbit/s for SU710, SU730 and SU730B; 64Gbit/s for SU740), can be integrated into a channel box. Only in the case of the first channel box is the first slot already occupied by the system.

A channel box occupies two height units in the rack.

3 Operating the service processor

The service processor (SVP) is operated under menu guidance via the SVP console window. The SVP console window is made available by the SE Manager when the SVP console is called.

Jobs are assigned to the service processor via special SVP frames (in this chapter abbreviated to: frames). All the information you require as an operator working with the frames can be found in this chapter.

After switching on the MU and the Server Unit, BS2000 operation must be prepared, i.e. the BS2000 operating system must be loaded (IPL = Initial Program Load). The following activities may be required for the IPL:

- select the IORSF (Input/Output Resource File) and start the IMPL (Initial Micro Program Load)
This is only necessary if you want to load another IORSF.
- specify the operating mode (Native/VM2000)
This is only necessary if you want to change the mode setting.
- start IPL using PROGRAM LOAD FRAME
To do this you may have to redefine device parameters in the DETAIL-1 frame.
- configure an automatic IPL (POWER ON IPL)

The following sections provide examples of standard processing relevant to loading of BS2000. There is also an description of how to select a particular configuration and how to re-initialize the SVP.

Standard processing at the SKP console at a glance:

- Selecting IORSF
- Re-initializing SVP
- Setting up PROGRAM LOAD FRAME: PRESET-1
- Setting up PROGRAM LOAD FRAME: PRESET-2
- Setting the operating mode for "loading BS2000 / VM2000" using PROGRAM LOAD FRAME: DETAIL-2
- Executing IPL in PROGRAM LOAD FRAME: DETAIL-1

3.1 Opening the SVP console

- > Log in on the SE Manager as administrator, BS2000 administrator or BS2000 operator.

After you have logged in successfully, you can access the functions of the SE Manager and consequently also those for operating the operating system (BS2000 or VM2000) on the Server Unit.

- > Select *Systems* -> [*<se server> (SE<model>) -> <su-name>(SU</390>)*], *SVP console* tab.

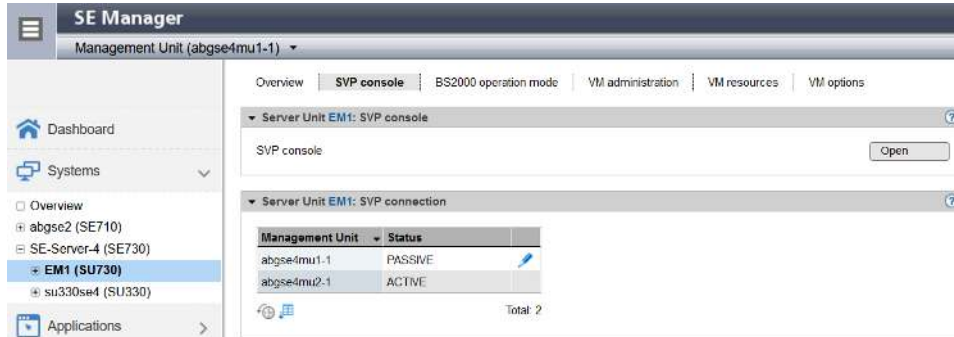

- > Click *Open* in the *SVP console* group to open a window with the SVP console. Information on console access can also be obtained in the SE Manager’s help.

A new window opens in which a terminal emulation sets up the connection to the SVP console:

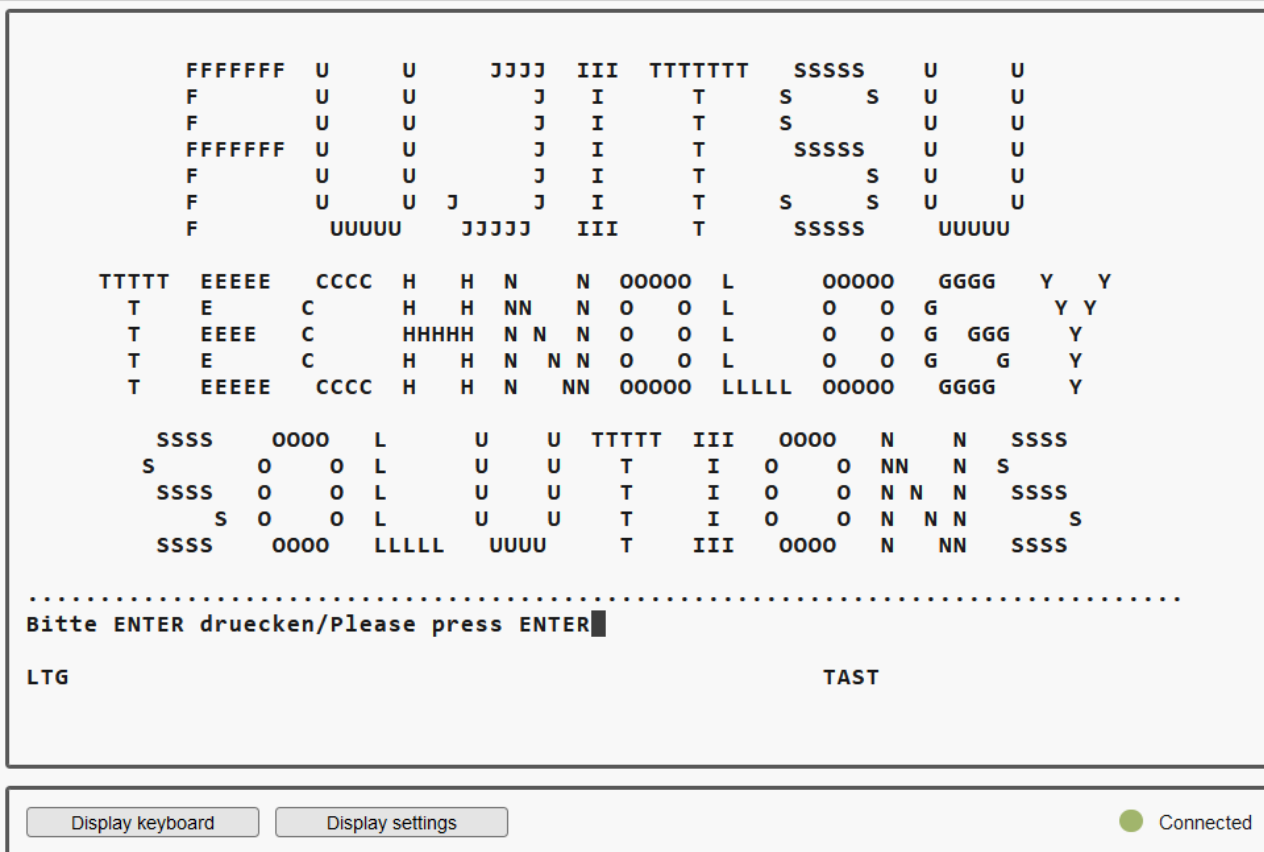

- > Confirm connection setup with the ENTER key.

After a brief wait time, the SVP frame below is displayed:

- After the server has been started: the MODE SELECTION FRAME (see “(ML) MODE SELECTION FRAME”)
- After the SVP console has been closed and opened again or when an SVP console has already been opened by another user: the last frame displayed.

! CAUTION!

When the SVP frame is opened again or when another SVP console is opened by another user, the window content is not displayed in full.

Click on CLEAR. This causes the screen to be refreshed, i.e. the frame that was last output is displayed again in its entirety.

If possible, the SVP should only be used via an SVP console. As frame outputs are sent to all active SVP consoles, operating multiple SVP consoles at the same time leads to them impairing each other.

3.2 General SVP frame structure

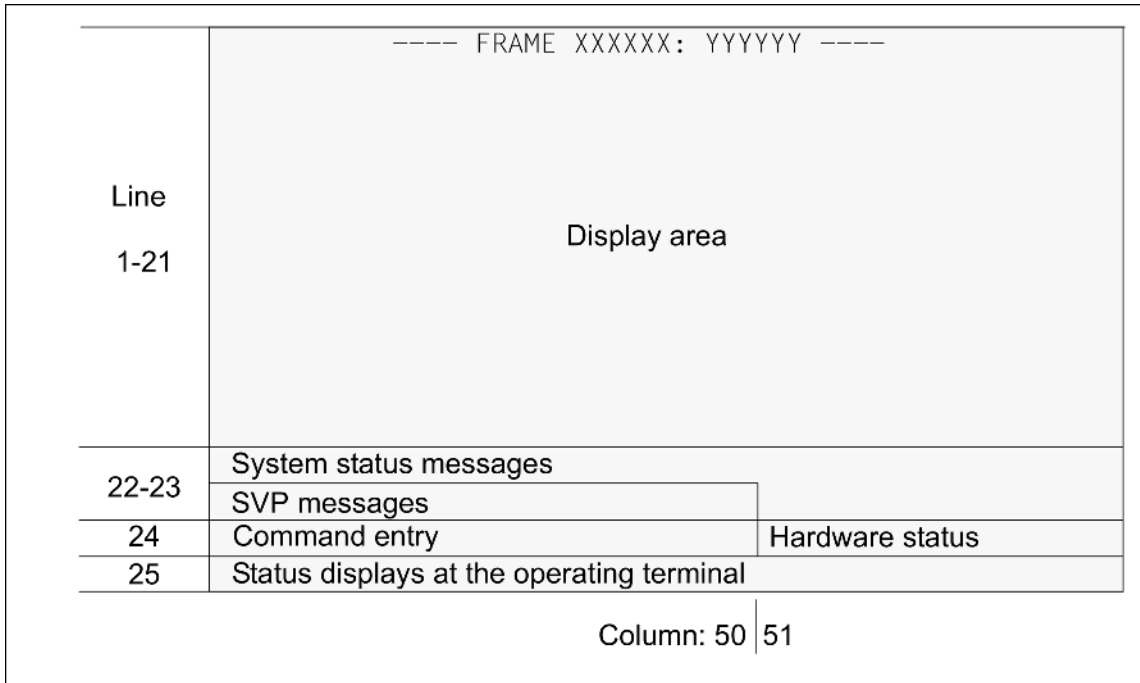

Figure 1: General structure of a frame

Each frame is divided into different areas:

- Lines 1 - 21 This is the display area of a frame. Here the functions and parameters that may be selected or output are displayed. Hardware-related information is also output.
- Line 22 + 23 System status messages and SVP messages are displayed here.
- Line 24 Commands can be entered here. Information on the hardware status is shown as of column 51.
- Line 25 This line is used for the status displays of the emulated console.

3.2.1 System status messages in line 22

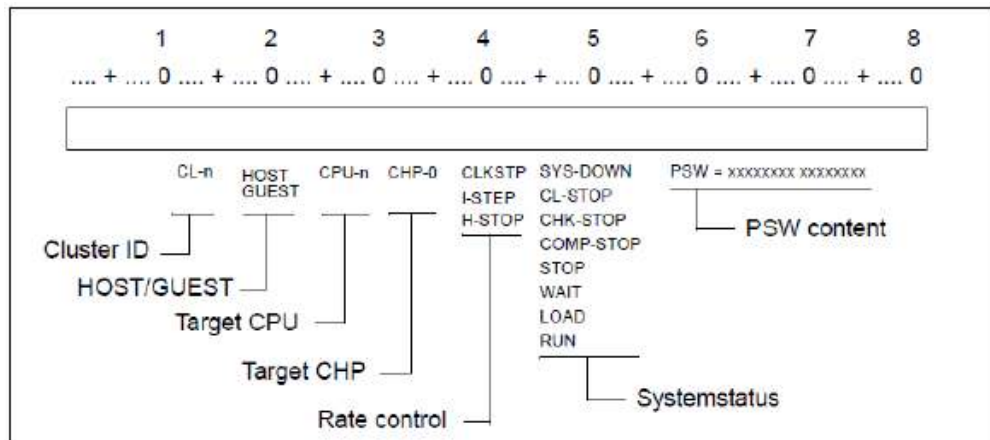

Figure 2: Format of the status display in line 22

Meaning of the status information in line 22:

Column	Display	Meaning
17 - 20	CL-n	Cluster ID of the Server Unit (n = 0 - 3)
22 - 26	none HOST GUEST	The system is operated in BS2000-NATIVE mode The selected CPU is occupied by the VM2000 monitor system The selected CPU is occupied by a VM2000 guest system
28 - 32	CPU-n	Display of the selected CPU (n = 0 - F); selection with PF16
34 - 38	CHP-0	Display of the channel processor CHP-0.
40 - 45	none CLKSTP I-STEP H-STEP	The system is in the normal status The system is in the clock-stop status The system is in the instruction step mode The system is in the hardware stop status
47 - 55	SYS-DOWN CL-STOP CHK-STOP COMP-STOP STOP WAIT LOAD RUN	The system is in the system down status The cluster is in the clock stop status The selected CPU is in the CHECK stop status The address comparison stop mode is active and the selected CPU is in the address comparison stop status The selected CPU is in the stop status The selected CPU is in the wait status An IPL is executed via the selected CPU The selected CPU is in the run status
58 - 80	none PSW =	The system is in the run status The system is in the stop status on the PSW address (PSW=Program Status Word)

3.2.2 System status messages in line 23

The following picture shows the extended area of the system status messages in line 23:

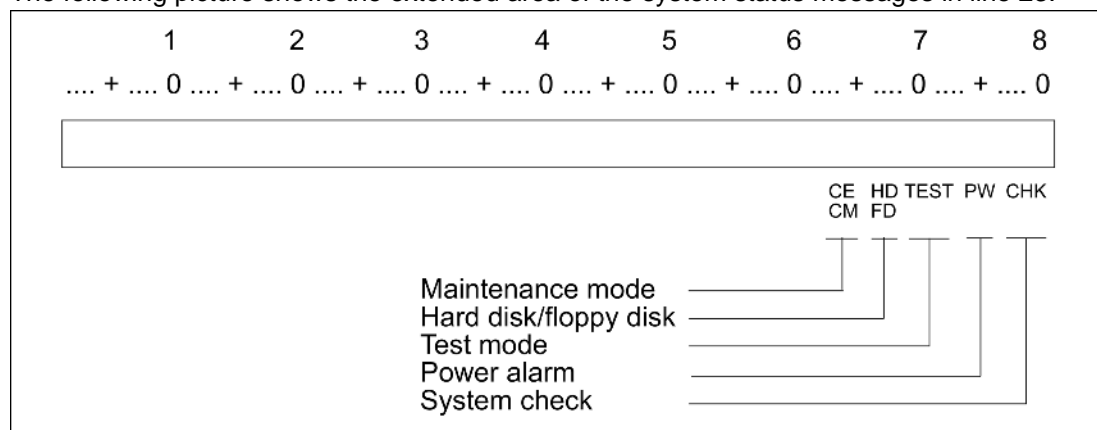

Figure 3: Format of the extended area of the status display in line 23

Meaning of the status messages in line 23:

Column	Display	Meaning
63 - 64	none CE CM	The SVP is in user mode The SVP is in maintenance mode The SVP is in hot system maintenance mode
66 - 67	HD FD	Hard disk 2 or MO (Magneto Optical disk) is online A formatted floppy disk is mounted in the FD drive
70 - 73	none TEST	The system is in the user mode The system is in test mode = maintenance mode (display together with CE)
75 - 76	none PW	The power supply is okay (Power Warning) An error has occurred in the power supply of the server
78 - 80	none CHK	No machine error (machine check) A machine error occurred in the server

3.2.4 Status displays in line 25

Displays in line 25 of the SVP console and their meaning:

Column	Display	Meaning
2	R	The console is ready
3	A	The SVP is active
10 - 25	none	The SVP is ready for input
10	X	Input locked
12 - 25	WAIT SYSTEM NOT CONNECTED CONNECTING	After input the keyboard is locked until output is completed Keyboard still locked because of SVP activity The MU has no connection to the SVP A connection to the SVP is being set up
31	none T	The system is in user mode The system is in test mode = maintenance mode
32	none S	The selected CPU is in the run status The selected CPU is in the stop status
33	none W	The selected CPU is in the run status The selected CPU is in the wait status
61 - 70	[] - [] 00	Status display for hardcopy printers This display is irrelevant for the MU
	For a redundant MU:	
	ACTIVE	This MU has a connection to the SVP
	NOT ACTIVE	The other MU has a connection to the SVP

If a write console message is output (e.g. SHUTDOWN COMPLETED), line 25 is displayed in the format of the terminal emulation, and the BEL icon is displayed.

```

cccccccccccccccccccccccccccccccccccccccccccccccccccccccccccc FLAG CODE = D90557 X 0000H00
LINE           BEL           KEYB ERR           EM:1
    
```

Column	Display	Meaning
1 - 3	LTG	Connection is established
21 - 23	BEL	Signal
56 - 59	TAST	Keyboard is connected
61 - 64	FEHL	Input when keyboard is locked
76 - 79	EM:1	Emulation level 1

To delete the message and switch the display of line 25, click on ModSel.

3.3 Using SVP frames

You assign a job to the SVP by invoking the relevant frame, selecting the desired function, and specifying the required parameters. To select a function or specify a parameter, you must enter the alphanumeric characters shown in the frame in the input fields marked by an arrow (=>). After you have completely filled out an input field with limited length, the cursor automatically switches to the next entry field. You can select entry fields manually with the tabulator key or arrow keys. Once you have entered all the functions and parameters assigned to a job, press the ENTER key. In some frames, SVP functions can also be initiated by actuating the corresponding function key (also known as pfkey).

Instead of selecting a function, you can also enter a command in the command input line in all frames (screen line 24) and assign a job to the SVP in this way. Frames can also be selected using the `FR <Frame-ID>`, e.g. `FR ML` (to switch to the MODE SELECTION FRAME, in upper or lower case). A command entered in line 24 takes priority over a selected frame function.

3.3.1 SVP functions (function keys)

A virtual keyboard is available to you for making entries on the SVP console.

- > Click *Display keyboard* below the window to open the virtual keyboard. If the keyboard is displayed, clicking *Hide keyboard* hides it.

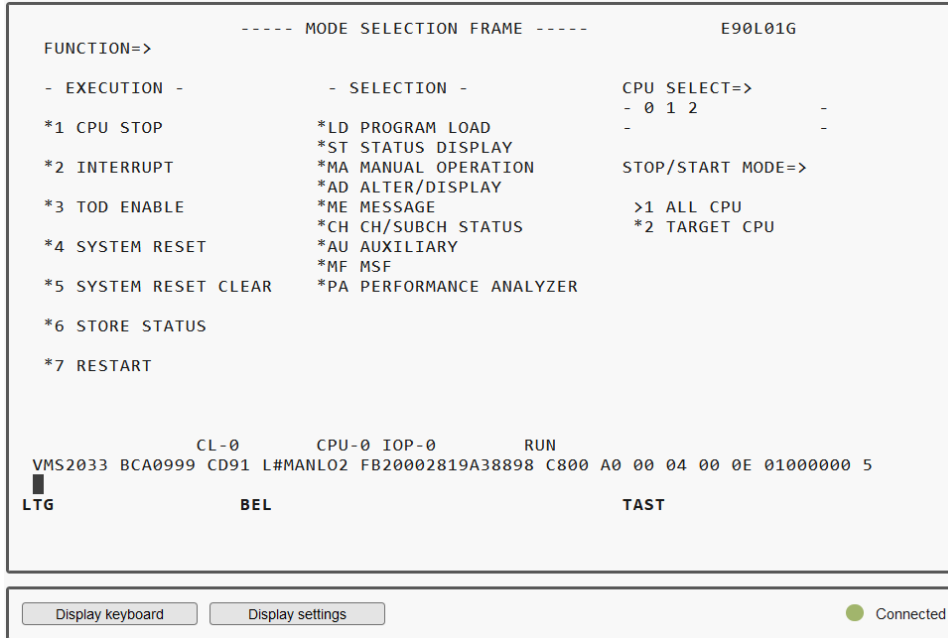

Function keys (pfkeys) PF1 through PF24 and Clear and Cancel are located in the upper part of the virtual keyboard. You can trigger the corresponding SVP functions by clicking with the mouse.

Some function keys are labeled with the name of the function they are most frequently used for (e.g. Index instead of PF2).

Function key PF20 (stop function) has no function in order to provide protection against it being pressed inadvertently and is therefore not offered on the virtual keyboard.

Table 1 shows the function keys and their functions which are applicable for most frames. Any different function allocations of function keys are described in the frames concerned. As an alternative, SVP functions can be called and entries made in the frames using your keyboard.

i Some of the function keys listed here only have a function in CE mode (CE=Customer Engineer, maintenance mode) and are used solely by Customer Support personnel. Customer Support can enable and disable CE mode on the server using a sliding switch on the inside of the maintenance panel or on the MU using a CLI command.

PF..	Function key of the virtual keyboard	Alternative entry on the keyboard	Name	Function
PF1	PF1	ESC F1	Help	Help functions

PF2	Index	ESC F2	Index	Only effective in CE mode: switches to the index frame.
PF3	Return	ESC F3	Return	Switches to the preceding frame.
PF4	PF4	ESC F4		Frame-specific function is performed.
PF5	PF5	ESC F5		Frame-specific function is performed.
PF6	Can / Erase	ESC F6	Cancel/ Erase Input	Command or input data is deleted.
PF7	Page up	ESC F7	Page up	The previous screen contents are displayed
PF8	Page down	ESC F8	Page down	The next screen contents are displayed
PF9	PF9	ESC F9		Frame-specific function is performed.
PF10	PF10	ESC F10		Frame-specific function is performed.
PF11	PF11	ESC SHIFT F1		Frame-specific function is performed.
PF12	PF12	ESC SHIFT F2		Frame-specific function is performed.
PF13	Recall	ESC SHIFT F3	Recall	Previous SVP commands are displayed in the command line. They can then be executed again with changed operands.
PF14	PF14	ESC SHIFT F4		Frame-specific function is performed.
PF15	PF15	ESC SHIFT F5		Frame-specific function is performed.
PF16	PF16	ESC SHIFT F6	Change CPU	Selects the CPU for which the subsequent commands are to apply. This CPU is then connected logically with the SVP.
PF17	PF17	ESC SHIFT F7		not assigned
PF18	Step	ESC SHIFT F8	Step	Executes the next command if the server is in Single Cycle Instruction Mode
PF19	PF19	ESC SHIFT F9	ARMSS management	Changes the user rights of an existing ARMSS connection
PF20		ESC SHIFT F10	Stop	Only effective in CE mode: Stops the selected CPU
PF21	Start	SHIFT F5	Start	Starts the selected CPU
PF22	PF22	SHIFT F6		not assigned
PF23	ModSel	SHIFT F7	Mode Select	<ul style="list-style-type: none"> – Switches to the MODE SELECTION FRAME – Erases WRITE-CONSOLE message on the screen (e.g. SHUTDOWN COMPLETED) – Erases BEL display in screen line 25

PF24	ModChg	F7	ModeChange	Switches back and forth between FJ-PROGRAM FRAME and SVP FRAME (for Customer Support only if appropriate settings apply!)
	Cancel	F5	Cancel/Reset	Cancel input, release keyboard
	Clear	F6	Refresh /Clear	The last frame output is displayed again. All inputs of the current frame made to date are reset.

Table 1: Function keys for SVP functions (part 1 of 2)

3.3.2 Switching between SVP frames

A switch between the frames is only possible within a specified scheme or via an FR command. The possible switches between the frames are possible:

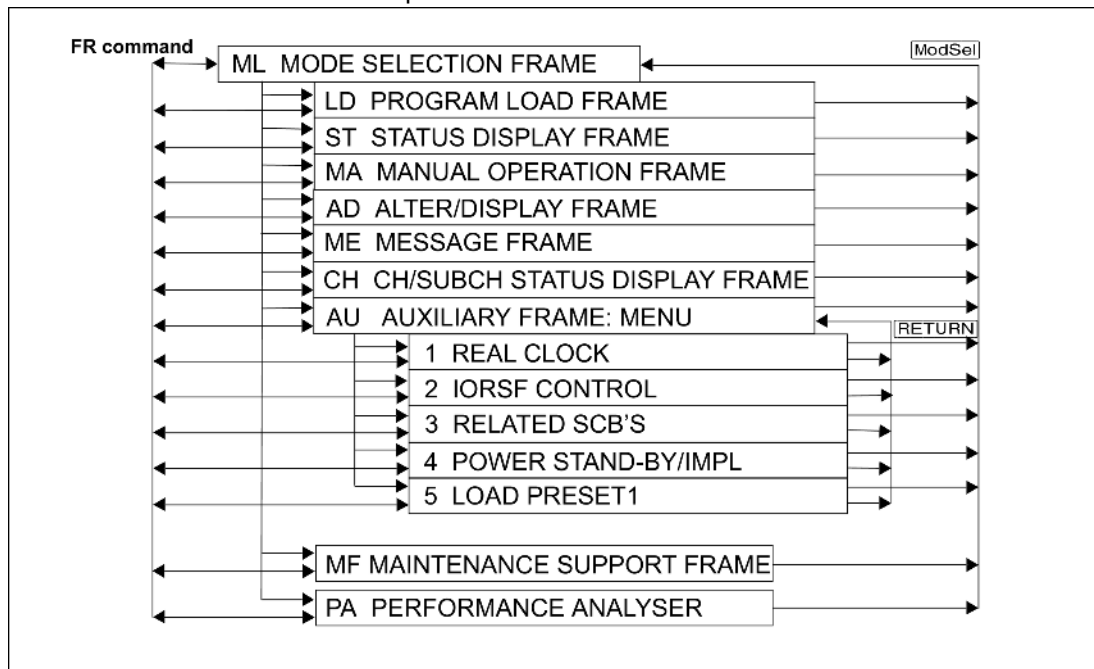

Figure 5: Switching between the frames

Explanation of the figure:

The frames are represented by this symbol:

ML MODE SELECTION FRAME

Each frame has an ID consisting of two letters derived from the frame name. In the above example the MODE SELECTION FRAME is also shown with the ID ML.

Arrows and SVP functions show how and with which button you can switch to another frame.

3.3.3 Options for switching between frames

The following table shows the options for switching to another frame in the SVP window.

Button	Effect
Index	Only in CE mode: by clicking on this button you switch from any frame directly to the index frame. The selection of the desired frame can then be made by entering the frame ID in the index frame.
Return	This button switches back to the previous frame or to the higher-level frame.
ModSel	This button switches from any frame to the MODE SELECTION FRAME.
Frame selection	Enter a frame code in the MODE SELECTION FRAME (e.g. ST, AU, AU5)
Change to subframes	You can change to a subframe by selecting it from the main frame or from a subframe that has already been invoked. This can be done: <ul style="list-style-type: none"> – with SVP function calls (the buttons are shown in the corresponding frame or subframe) – by selecting a function with or without entering a parameter.
FR command	It is possible to switch to any frame with the FR command. The command is entered in the command line (screen line 24) of a frame. It has the following format: FR XX (XX is the code of the desired frame; see figure 5 “Switching between the frames”)

3.4 SVP frames and subframes

The frames are used by the operator for sending jobs to the SVP and for receiving replies from the SVP.

Some frames have up to seven subframes. The subframes contain other, more detailed functions and information which does not fit in the main frame.

Several frames display settings stored by the SVP. The current setting is indicated by an “>” arrow before the corresponding menu item. An example of this is provided in [figure 6](#): STOP/START MODE applies only for the target CPU (selected CPU).

i This manual only describes the frames required by the operator.

3.4.1 (ML) MODE SELECTION FRAME

```

          ----- MODE SELECTION FRAME -----          E90L01G
FUNCTION=>
- EXECUTION -          - SELECTION -          CPU SELECT=>
          *1 CPU STOP          *LD PROGRAM LOAD          - 0 1 2 3 4          -
          *2 INTERRUPT          *ST STATUS DISPLAY          -          -
          *3 TOD ENABLE          *MA MANUAL OPERATION          STOP/START MODE=>
          *4 SYSTEM RESET          *AD ALTER/DISPLAY          *1 ALL CPU
          *5 SYSTEM RESET CLEAR          *ME MESSAGE          >2 TARGET CPU
          *6 STORE STATUS          *CH CH/SUBCH STATUS
          *7 RESTART          *AU AUXILIARY
          *MF MSF
          *PA PERORMANCE ANALYZER
          CL-0          CPU-0 CHP-0          RUN
RA          []-[ ]00
    
```

Figure 6: MODE SELECTION FRAME screen

By making entries in this frame and pressing the ENTER key, you can switch to other frames or execute various basic functions.

FUNCTION => The desired function can be selected by entry of a number listed in the EXECUTION column or a letter combination listed in the SELECTION column.

SELECTION => After entering the appropriate letter combination you can switch to the following SVP frames:

LD	PROGRAM LOAD	Load BS2000	“(LD) PROGRAM LOAD FRAME: BASIC”
ST	STATUS DISPLAY	Display status	“(ST) STATUS DISPLAY FRAME”
MA	MANUAL OPERATION	Manual operations	“(MA) MANUAL OPERATION FRAME”
AD	ALTER/DISPLAY	Alter/display storage/register	“(AD) ALTER/DISPLAY FRAME”
ME	MESSAGE	Display message	“(ME) MESSAGE FRAME”
CH	CH/SUBCH STATUS	Display status of channel /subchannel	“(CH) CH/SUBCH STATUS DISPLAY FRAME”
AU	AUXILIARY	Auxiliary controls	“(AU) AUXILIARY FRAME”
MF	MSF	Display FLAG codes	“(MF) MSF FRAME”
PA	PERORMANCE ANALYZER	Performance analysis	“(PA) PERFORMANCE ANALYZER FRAME”

EXECUTION The following function is executed after the corresponding number has been entered:

! CAUTION!

The functions are executed according to the entries in the CPU SELECT and STOP/START MODE fields (see table on next page)!

1	CPU STOP	stops either the CPU selected in the CPU SELECT and STOP/START MODE fields or all CPUs
2	INTERRUPT	creates an external interrupt for the CPU selected in the fields CPU SELECT and STOP/START MODE
3	TOD ENABLE	time entry is enabled
4	SYSTEM RESET	all CPUs, channel processors, channels and controllers are reset
5	SYSTEM RESET CLEAR	as 4; in addition, the working memory is erased
6	STORE STATUS	selected CPU is stopped, the status is stored
7	RESTART	starts the system again (this function is only possible if the operating system is restart-capable) In VM2000 mode a restart of the monitor system (with SLED) will be initiated.

CPU SELECT => A particular CPU can be selected here for the functions in the EXECUTION selection menu (see the previous page).
The CPUs available are displayed in the two lines below this.

0 ... F Selection of a particular CPU

STOP /START MODE => This can be used to indicate whether the functions in the EXECUTION selection menu are to be carried out for all CPUs or only for the CPU in the CPU SELECT field.

1	ALL CPU	all CPUs are selected
2	TARGET CPU	only the CPU selected in the CPU SELECT field is selected

The following table shows all the functions that can be meaningfully combined:

Function	CPU SELECT	STOP/START MODE	Effect on:
CPU STOP	-	1 All CPU	all CPUs
	0 ... F	2 TARGET CPU	selected CPU
INTERRUPT STORE STATUS RESTART	0 ... F	2 TARGET CPU	selected CPU
TOD ENABLE SYSTEM RESET SYSTEM RESET CLEAR	-	-	all CPUs

--: unusable

3.4.2 (LD) PROGRAM LOAD FRAME: BASIC

```

----- PROGRAM LOAD FRAME: BASIC -----          E90L01G
-LOAD FUNCTION-
==>
*1 START AUTO
*2 START FAST
*3 START DIAL
*4 START
*5 SYSTEM DUMP

                                *ENTER   EXECUTE
                                *PF7     GO TO DETAIL-1
                                *FR AU5   GO TO PRESET(AU5 FRAME)
                                RUN

CL-0      CPU-0 CHP-0

RA                                               []-[ ]00

```

Figure 7: PROGRAM LOAD FRAME: BASIC screen

An IPL is executed by entering a load function and pressing the ENTER key. The predefined parameters in (AU5) AUXILIARY FRAME: LOAD PRESET are used.

LOAD FUNCTION ==> The following function is selected after the corresponding number has been entered:

1	START AUTO	executes IPL: automatic startup
2	START FAST	executes IPL: fast startup
3	START DIAL	executes IPL: dialog startup
4	START	not used
5	SYSTEM DUMP	executes SLED

Frame-specific functions

ENTER Executes IPL / SYSTEM DUMP

After making your entries in the mask and pressing the ENTER key, the following prompt will appear:

```
*****  
*  
* ARE YOU SURE ? (ENTER Y OR N) N *  
*  
*****
```

! CAUTION!
The IPL must not be executed during system operation! If this instruction is not heeded, BS2000 will be aborted!

> Press the Y and ENTER keys to execute the IPL, or N and ENTER to cancel the procedure.

Page up Swap to PROGRAM LOAD FRAME: DETAIL-1 (see below)

FR AU5 Enter the frame command in line 24:
Swap to AUXILIARY FRAME: LOAD PRESET1 (see "(AU5) AUXILIARY FRAME: LOAD PRESET1")

3.4.2.1 (LD) PROGRAM LOAD FRAME: DETAIL-1

```

----- PROGRAM LOAD FRAME: DETAIL-1 ----- E90L01G
-LOAD FUNCTION-                -IPL DEVICE-
==>                            ==> 2
*1 START AUTO                  *1 PRESET GROUP -----+
*2 START FAST                  >*2 CURRENT GROUP -----+ |
*3 START DIAL                  *3 UNIT ADDRESS  -+      +      +
*4 START                        A108    A108    A108
*5 SYSTEM DUMP                  XXXX    XXXX
*6 LOAD CLEAR -----+        XXXX    XXXX
*7 LOAD NON CLEAR  -+ XXXX XXXX
                                |
                                +MT CONTROL-          --- DETAIL-2  STATUS  --
PARMS=> 1                        ==> 1                VM  MODE :  AVM/EX
                                >*1 NL                  EXA  MODE :  ENABLE
                                *2 SL                  IPL  EXEC :  ENABLE
                                *3 NL-REWIND
                                *4 SL-REWIND            *ENTER   EXECUTE
                                                *PF3    GO TO BASIC FRAME
                                                *PF9    GO TO DETAIL-2

                                CL-0      CPU-0 CHP-0      RUN
RA                                [ ]-[ ]00

```

Figure 8: PROGRAM LOAD FRAME: DETAIL-1 screen

By making entries in this frame and pressing the ENTER key you can control the execution of an IPL.

Before completing this frame, check whether the correct firmware for operating Native BS2000 or VM2000 has been loaded by the SVP. Information on this is provided in the DETAIL-2 STATUS field.

DETAIL-2 STATUS In this position the current settings of the PROGRAM LOAD FRAME: DETAIL-2 are displayed. VM MODE shows the loaded firmware:

- NATIVE for BS2000 operation
- AVM/EX for VM2000

If the setting is not correct, click on PF9 to correct the entry in PROGRAM LOAD FRAME: DETAIL-2. After you have made the correction and clicked on PF9, the setting is stored and you are returned to this frame (see “(LD) PROGRAM LOAD FRAME: DETAIL-2”).

If the setting is correct, complete this frame and execute the IPL.

LOAD FUNCTION ==> The following function is selected after the corresponding number has been entered:

1	START AUTO	executes IPL: automatic startup
2	START FAST	executes IPL: fast startup
3	START DIAL	executes IPL: dialog startup

4	START	not used
5	SYSTEM DUMP	executes SLED
6	LOAD CLEAR	clears main memory before IPL
7	LOAD NON CLEAR	does not clear main memory before IPL

Functions 6 or 7 must be used for an IPL from a real or emulated tape device. In addition, function 3 must be selected at MT CONTROL (see “(LD) PROGRAM LOAD FRAME: DETAIL-1”).

IPL DEVICE ==> By entering the corresponding number in this field you can specify from which device group an IPL is to be executed.

1	PRESET GROUP	The first device address in this column is the device from which an IPL is to be executed. The order and number were specified previously in (AU5) AUXILIARY FRAME: LOAD PRESET-1. If IPL is terminated normally, the device address list is transferred from the PRESET GROUP to the CURRENT GROUP. If the IPL is unsuccessful, the next device address from the PRESET GROUP is reloaded. If this loading is terminated normally, this device address heads the CURRENT GROUP.
2	CURRENT GROUP	The first device address in this column is the device from which the last IPL was executed. If the loading from this device is unsuccessful, the IPL is repeated with the next device address. If it is terminated normally, this address then heads the CURRENT GROUP.
3	UNIT ADDRESS	A new device address from which the operating system is to be loaded can be entered here. If the IPL is terminated normally, this device address is put in the first position in the CURRENT GROUP. If the IPL is unsuccessful, the loading is not repeated.

PARMS ==> A maximum of 8 characters can be entered in this field. Their position and meaning are listed below:

Position 1	'BLANK' 1	loading BS2000 loading VM2000
Position 2 - 5	mn	The mnemonic pair of an SKP console can be entered here if the standard consoles with the mnemonic pairs C2C3 and C4C5 are not available for the IPL.
Position 6 - 8		not used

MT CONTROL ==> IPL from tape:

1	NL	from current tape position
2	SL	skip label then load

3	NL-REWIND	rewind then load
4	SL-REWIND	rewind, skip label then load

Function 3 must be selected for an IPL of a real or emulated tape device.

Frame-specific function

ENTER Executes IPL / SYSTEM DUMP

After making your entries in the mask and pressing the ENTER key, the following prompt will appear:

```

*****
*
* ARE YOU SURE ? (ENTER Y OR N) N *
*
*****
    
```

! CAUTION!

The IPL must not be executed during system operation! If this instruction is not heeded, BS2000 will be aborted!

> Press the Y and ENTER keys to execute the IPL, or N and ENTER to cancel the procedure.

RETURN Swap to PROGRAM LOAD FRAME: BASIC (see [“\(LD\) PROGRAM LOAD FRAME: BASIC”](#))

PF9 Swap to PROGRAM LOAD FRAME: DETAIL-2 (see next page).

3.4.2.2 (LD) PROGRAM LOAD FRAME: DETAIL-2

```

----- PROGRAM LOAD FRAME: DETAIL-2 -----          E90L01G
-VM MODE-
==> 2
*1 NATIVE
>*2 AVM/EX

-IPL EXECUTION-
==> 1
>*1 ENABLE
*2 DISABLE

*ENTER EXECUTE
*PF3 GO TO BASIC FRAME
*PF9 GO TO DETAIL-1

CL-0          CPU-0 CHP-0          RUN
RA                                                    []-[100

```

Figure 9: PROGRAM LOAD FRAME: DETAIL-2 screen

By making an entry in this frame and pressing the ENTER key, you set the operating mode.

VM MODE ==> Selection of the firmware to be loaded from SVP

1	NATIVE	for BS2000 operation
2	AVM/EX	for VM2000

IPL EXECUTION ==> IPL execution

1	ENABLE	executes IPL
2	DISABLE	does not execute IPL

If there are changes to the VM MODE and IPL EXECUTION ==> 2, only the other firmware is loaded and no IPL is executed.

Frame-specific functions

ENTER Sets operating mode.

- > After selecting the firmware to be loaded in the VM MODE ==> field and entering 2 in the IPL EXECUTION ==> field, press the ENTER key.

The following prompt appears on the screen:

```
*****  
*                                     *  
* ARE YOU SURE ? (ENTER Y OR N) N *  
*                                     *  
*****
```

! CAUTION!
The operating mode must not be reset during system operation! If this instruction is not heeded, BS2000 will be aborted!

- > Press the Y key to reload the firmware, or the N key to cancel the procedure. Confirm your entry with the ENTER key.
- > After reloading the firmware, click on the PF9 key to carry out IPL in PROGRAM LOAD FRAME: DETAIL-1.

RETURN Swap to PROGRAM LOAD FRAME: BASIC (see [“\(LD\) PROGRAM LOAD FRAME: BASIC”](#))

PF9 Swap to PROGRAM LOAD FRAME: DETAIL-1 (see [“\(LD\) PROGRAM LOAD FRAME: DETAIL-1”](#)) without saving the changes you have made.

3.4.3 (ST) STATUS DISPLAY FRAME

```

----- STATUS DISPLAY FRAME -----
                                         E90L01G-03C+004
CPU-0 (#0) ONL RUN      IOP-0 ONL      SVP      CHEB-0
CPU-1 (#1) ONL RUN      IOP-1 ONL      POWER     CHEB-1
CPU-2 (#2) ONL RUN
CPU-3 (#3) ONL RUN
CPU-4 (#4) ONL RUN      MSU-0 ONL      CHEB-4
                        MSU-1 ONL

SYSTEM INFORMATION
MEMORY  8GB
MODE    AVM/EX
SVPM    ENABLE      AROMA ENABLE

CL-0      CPU-0 IOP-0      RUN
                                         CE    TEST

```

Figure 10: STATUS DISPLAY FRAME screen

This frame informs you about the current status of the server and its individual components (power on/off, online /offline, normal/maintenance state, etc.). Components which are not installed are not displayed. At most the following components are possible:

- CPU: CPU-0 through CPU-F
- I/O processor: IOP-0 through IOP-3
- Main Storage Unit: MSU-0 through MSU-3
- Channel box: CHEB-0 through CHEB-F

The important displays are the memory size, the addressing mode (MODE EXA or AVM/EX) and the availability of the SKP functionality (SVPM ENABLE display).

3.4.4 (MA) MANUAL OPERATION FRAME

```

----- MANUAL OPERATION FRAME ----- E90L01G-03C+004
FUNCTION=> █
*1 RATE CONTROL          RATE CONTROL=>
*2 ADRS COMPARE STOP    *1 PROCESS
                        *2 I-STEP
*3 FIRM DUMP
*4 HSA DUMP
*X EXECUTE

ADDRESS COMPARE STOP
ADRS TYPE=>
*1 ABSOLUTE
*2 LOGICAL

ADRS COMP SELECT=>
*1 ANY
*2 OPERAND FETCH (OFETCH)
*3 OPERAND STORE (OSTORE)
*4 INSTRUCTION ADRS (IA)
*5 IA & OFETCH
*6 OFETCH & OSTORE

ADRS SET=> XXXX
=> XXXXXXXXX

ADRS COMP MODE=>
*1 RESET
*2 SET
*3 NORMAL

CL-0      CPU-0 IOP-0      RUN
E2M31 CPU NOT IN STOPPED STATE                CE      TEST
    
```

Figure 11: MANUAL OPERATION FRAME screen

By making an entry in this frame and pressing the ENTER key, you can perform various manual operations.

Instructions on this frame are only executed when the CPU has been stopped (see message in frame line 23). The CPU status is displayed in line 22.

- > Selection of a CPU by clicking on PF16
- > Stopping of the selected CPU (see (ML) MODE SELECTION FRAME “(ML) MODE SELECTION FRAME”)

FUNCTION => The following function is executed after the corresponding character has been entered and the ENTER key has been pressed:

1	RATE CONTROL	defines program operation
2	ADRS COMPARE STOP3	sets mode for compare address stop
3	FIRM DUMP	outputs a firmware dump to tape, MTC or an emulated tape device (for Customer Support only)
4	HSA DUMP	executes HSA dump (for Customer Support only) (HSA Hardware/Software Area)
X	EXECUTE	executes functions 1 - 4

The following table shows the additional entries required for each of the four main functions in other input fields:

Function	Input field				
	RATE CONTROL	ADRS TYPE	ADRS COMPSELECT	ADRS SET	ADRS COMPMODE
1 RATE CONTROL	o	x	x	x	x
2 ADRS COMP STOP	x	o	o	o	o
3 FIRM DUMP	x	x	x	x	x
4 HSA DUMP	x	x	x	x	x

o: entry required

x: entry not possible

RATE CONTROL defines program operation

=>

1	PROCESS	continual program operation
2	I-STEP	step-by-step command execution

ADRS TYPE Entries for address compare stop:

=>

		entry under ADRS SET is
1	ABSOLUTE	absolute address
2	LOGICAL	a logical address

ADRS COMP SELECT => Address compare stop if compare stop address is same as

1	ANY	any address
2	OPERAND FETCH (OFETCH)	operand read address

3	OPERAND STORE (OSTORE)	operands write address
4	INSTRUCTION ADRS (IA)	instruction address
5	IA & OFETCH	instruction and operand read address
6	OFETCH & OSTORE	operand read and write address

ADRS SET => Compare stop address

XXXX	address space larger than 32 bits
XXXXXXXX	32-bit address

ADRS COMP MODE => Address compare stop mode

1	RESET	Switches off address compare stop and resets address compare stop conditions in the fields ADRS TYPE, ADRS COMP SELECT and ADRS SET
2	SET	Switches on address compare stop
3	NORMAL	Switches off address compare stop

i Changes in this frame are reserved for the Customer Support.

3.4.5 (AD) ALTER/DISPLAY FRAME

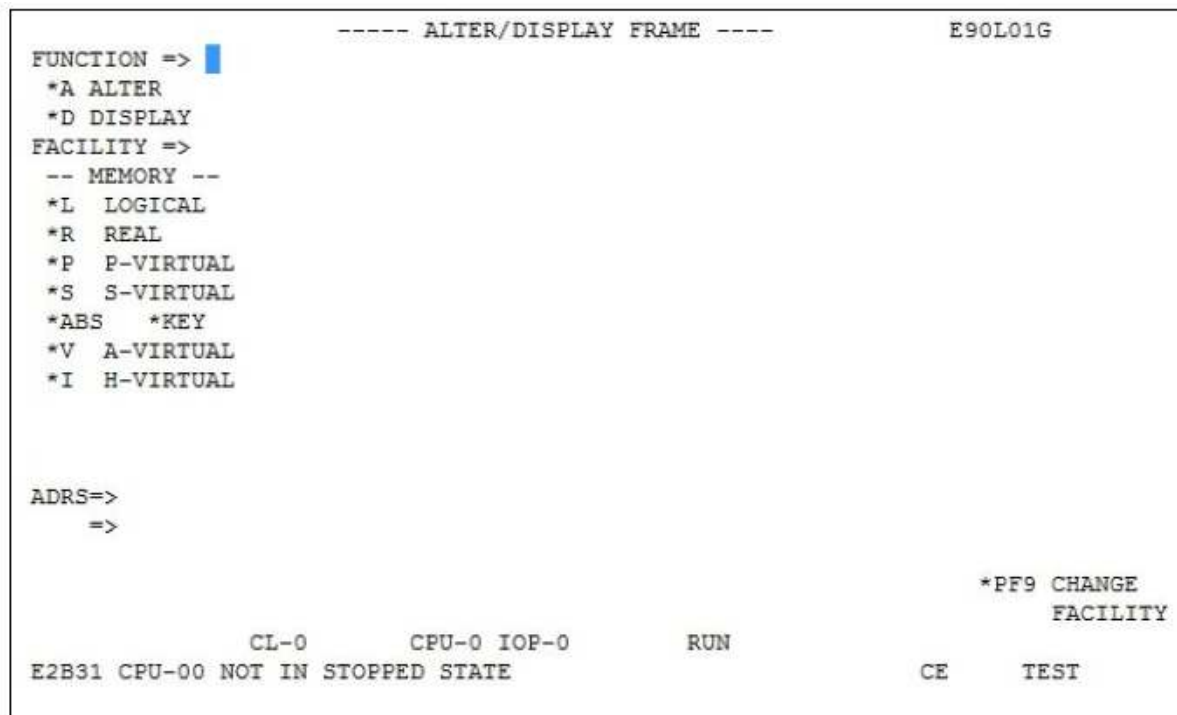

Figure 12: ALTER/DISPLAY FRAME screen

By making an entry in this frame and pressing the ENTER key, you can use this frame to display and change the contents of the main memory and the memory protect key.

Instructions on this frame are only executed when the CPU has been stopped (see message in frame line 23). The CPU status is displayed in line 22.

- > Selection of a CPU by clicking on PF16
- > Stopping of the selected CPU (see (ML) MODE SELECTION FRAME “(ML) MODE SELECTION FRAME”)

FUNCTION => The following function is selected after the corresponding letter has been entered:

A	ALTER	change and modify memory contents
D	DISPLAY	display memory contents

FACILITY => Possible displays of memory areas with various addresses:

L	LOGICAL	logical storage address
R	REAL	real storage address
P	P-VIRTUAL	primary virtual storage address
S	S-VIRTUAL	secondary virtual storage address

ABS		absolute address
KEY		memory protect key
V	A-VIRTUAL	address space virtual address
I	H-VIRTUAL	basic address space virtual address

ADRS => Memory address

XXXX	address space larger than 32 bits
XXXXXXXX	32-bit address

Frame-specific functions

PF9 When you click on this button, the following subframe is displayed:

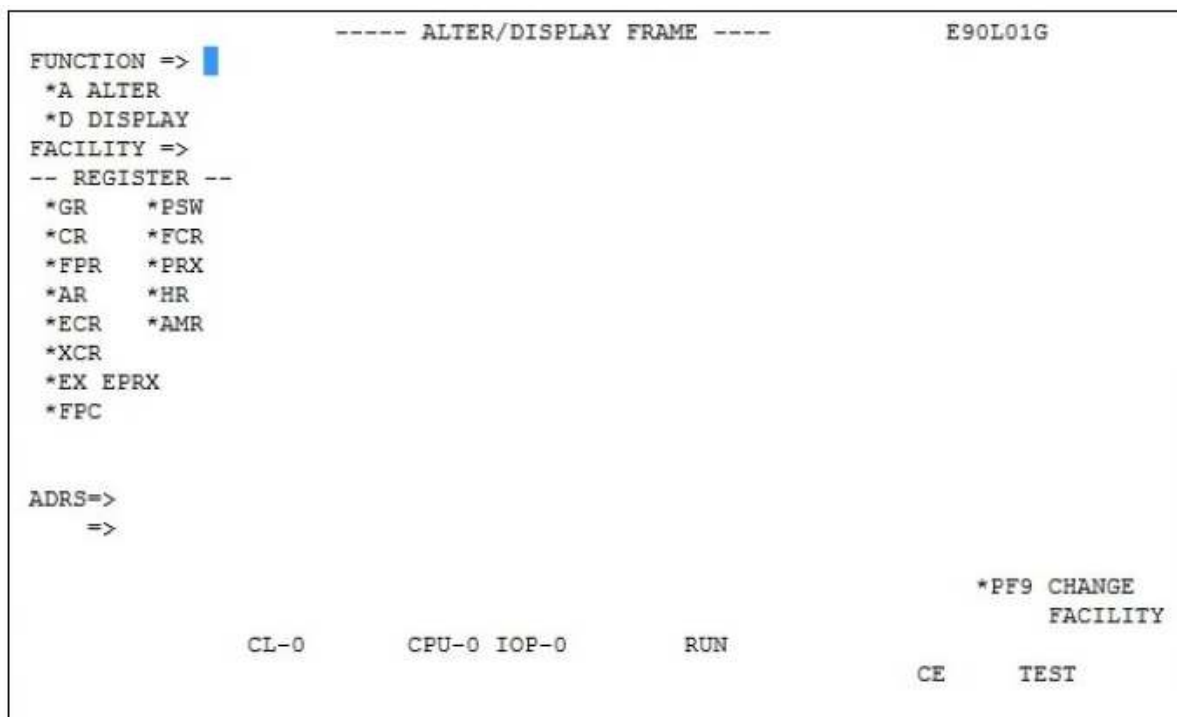

Figure 13: ALTER/DISPLAY FRAME screen

By making the appropriate entries and pressing the ENTER key, you can use this frame to change and display the contents of important CPU registers.

Instructions on this frame are only executed when the CPU has been stopped (see message in frame line 23). The CPU status is displayed in line 22.

- > Selection of a CPU by clicking on PF16
- > Stopping of the selected CPU (see (ML) MODE SELECTION FRAME “(ML) MODE SELECTION FRAME”)

FUNCTION => The following function is selected after the corresponding letter has been entered:

A	ALTER	change and modify register contents
D	DISPLAY	display register contents

FACILITY => Possible displays of registers:

GR	General register
PSW	Program status word
CR	Control register
FCR	Feature control register
FPR	Floating-point register
PRX	Prefix register
AR	Access register
HR	Hyper register
ECR	Extended control register
AMR	Address modulation register
XCR	Extended control register
EX EPRX	Extended prefix register
Additional display, if IEEE Arithmetic Operation Mechanism is activated:	
FPC	Floating point control register

ADRS => no input required

Frame-specific functions

PF9 returns to the frame for memory display

i Changes in this frame are reserved for the Customer Support.

3.4.6 (ME) MESSAGE FRAME

```

----- MESSAGE FRAME -----
NEWEST LINE = 0776
LINE ID MESSAGE MM/DD HH:MM:SS
0759 01 X2LA9 FUNCTION: ST 03/25 14:47:23
0760 01 X2SA9 SSU0 03/25 14:48:56
0761 01 E2SA1 COMMAND NOT FOUND 03/25 14:48:56
0762 01 X2SA9 PF 8 03/25 14:49:14
0763 01 X2SA9 PF 3 03/25 14:50:30
0764 01 X2LA9 FUNCTION: MA 03/25 14:50:35
0765 01 E2M31 CPU NOT IN STOPPED STATE 03/25 14:50:35
0766 01 X2MA9 PF 2 03/25 14:51:47
0767 01 E2MA2 UNSUPPORTED PF KEY 03/25 14:51:47
0768 01 X2MA9 PF 3 03/25 14:51:56
0769 01 X2LA9 FUNCTION: AD 03/25 14:52:10
0770 01 E2B31 CPU-0 NOT IN STOPPED STATE 03/25 14:52:11
0771 01 X2BA9 PF 9 03/25 14:53:48
0772 01 X2B00 COMMAND COMPLETED 03/25 14:53:48
0773 01 X2BA9 PF 2 03/25 14:54:49
0774 01 E2BA2 UNSUPPORTED PF KEY 03/25 14:54:49
0775 01 X2BA9 PF 3 03/25 14:55:15
0776 01 X2LA9 FUNCTION: ME 03/25 14:55:20
CL-0 CPU-0 CHP-0 RUN
RA []-[ ]00

```

Figure 14: MESSAGE FRAME screen

All SVP messages and commands to the SVP are stored in a message file. They can be viewed in the MESSAGE FRAME.

Frame-specific functions

- Page down one page forwards, in the direction of the newer entries
- Page up one page backwards, in the direction of the older entries
- PF11 one page to the right for the display of long messages
- PF10 one page to the left

Entering a line command in line 24 permits you to display a certain entry in the uppermost line.

Example: L 0700

3.4.7 (CH) CH/SUBCH STATUS DISPLAY FRAME: CHANNEL

```

----- CH/SUBCH STATUS DISPLAY FRAME: CHANNEL -----      E90L01G
IOP-0
PCHAD 0000000000000000 0000000000000000 0000000000000000 0000000000000000
0000000000000000 1111111111111111 2222222222222222 3333333333333333
0123456789ABCDEF 0123456789ABCDEF 0123456789ABCDEF 0123456789ABCDEF

CHPID 0000000000000000 0000000000000000 0000000000000000 0000000000000000
0000000000000000 1111111111111111 2222222222222222 3333333333333333
0123456789ABCDEF 0123456789ABCDEF 0123456789ABCDEF 0123456789ABCDEF

INSTALLED *.*****.**** *.....**.....
OP        ..*****.**** ..**.....
ON-LINE   *.*****.**** *.....**.....
CH-TYPE   F FFFFFFFF FFFF C      FF
          C CCCCCCCC CCCC N      CC
          N P P P P P P P P P P C      P P

FUNCTION =>
1 CH STATUS      IOP NO.=>          4 FC PORT STATUS
2 SUBCH STATUS   CHPID =>          LCHADR=>      5 ONA PORT STATUS
                 LINKADR=>        LCUADR=>        *PF10 PREV
3 LINK STATUS    PCHAD =>          *PF11 NEXT
                 CL-0      CPU-0 IOP-0      RUN
                                     CE      TEST
    
```

Figure 15: CH/SUBCH STATUS DISPLAY FRAME: CHANNEL screen

By making entries in the input fields and pressing the ENTER key, you display the status of the I/O system. Further subframes are supplied in conjunction with FUNCTION 2 to 5.

FUNCTION => The following information is displayed on the screen after the corresponding number has been entered:

1	CH STATUS	channel status (additional input in IOP NO field)
2	SUBCH STATUS	subchannel status (additional input in the fields CHPID and LINKADR)
3	LINK STATUS	LINK status of a type-S channel (type-S channel not supported on SU /390)
4	FC PORT STATUS	Port status of a type-FC channel
5	ONA PORT STATUS	Port status of an ONA channel (Optical Network Adapter, not supported by BS2000)

IOP NO => channel processor

0 ... 7

CHPID =>	channel path number
000 ... 0FF	
LCHADR =>	logical channel address no input required
LINKADR =>	link address for type-S channel (not supported on SU /390)
LCUADR =>	logical control unit address no input required
PCHAD =>	physical channel address
000 ... 0FF	

Frame-specific functions

- PF10 Display of channels with lower addresses.
- PF11 Display of channels with higher addresses.

3.4.8 (AU) AUXILIARY FRAME: MENU



Figure 16: AUXILIARY FRAME: MENU screen

You can move to other frames by making entries in this menu frame and pressing the ENTER key.

SELECTION => The following subframes are displayed on the screen by entering the appropriate number:

1	REAL CLOCK	displaying/setting SVP clock	"(AU1) AUXILIARY FRAME: REAL CLOCK"
2	ORSF CONTROL	displaying/editing IORSF	"(AU2) AUXILIARY FRAME: IORSF CONTROL"
3	RELATED SCB	memory size for related SCBs	"(AU3) AUXILIARY FRAME: RELATED SCB'S"
4	POWER STAND-BY /IMPL	executing POWER STAND-BY or IMPL	"(AU4) AUXILIARY FRAME: POWER STAND-BY/IMPL"
5	LOAD PRESET	presetting LOAD FRAME	"(AU5) AUXILIARY FRAME: LOAD PRESET1"

3.4.8.1 (AU1) AUXILIARY FRAME: REAL CLOCK

```

----- AUXILIARY FRAME: REAL CLOCK -----          E90L01G-03C+030

          YYYY MM DD   HH MM SS
          2015.01.25   15:26:47
          -

                                          *PF6   CANCEL
                                          *PF12  TIMER SET

CL-0          CPU-0  CHP-0          RUN
RA                                                    []-[ ]00

```

Figure 17: AUXILIARY FRAME: REAL CLOCK screen

When the screen is invoked, the current date and time of the SVP are displayed.

Corrections can be entered in the line below. These corrections take effect when you click on PF12.

i The SVP clock is synchronized by the MU (message in line 23: SET TIME COMMAND COMPLETED). The MU time is taken over by the SVP here.

As a consequence, an incorrect time specification in the MU has to be corrected in the SVP.

The administrator can set the local time in the MU in the SE Manager using the *System time* tab in the menu *Hardware -> Units [-> <se server> (SE<model>)] -> <mu-name> (MU) -> Management* (see the “Operation and Administration” manual [7]).

Frame-specific functions

Can/Erase Delete input

PF12 Corrections are carried out by the SVP

3.4.8.2 (AU2) AUXILIARY FRAME: IORSF CONTROL

```

----- AUXILIARY FRAME: IORSF CONTROL -----          E90L01G

NO.    COMMENT
0      SU700001SU700-29001 / DISK DET. DX600-AENDERUNG / 13.11.14
      DATE 2014.11.13      TIME 09:07      TYPE-1
1      SU700001SU700-29001 / ERW. DX440-S2-1 AUF 256 DVC / 04.08.14
      DATE 2014.10.21      TIME 15:41      TYPE-1
2      SU700001SU700-29001 / ALLE PLATTEN ATTACHED / 05.11.14
      DATE 2014.11.05      TIME 13:42      TYPE-1
3      SU700001SU700-29001 / ERW. DVC F6E0 BIS F6EF / 21.10.14
      DATE 2014.10.21      TIME 13:33      TYPE-1

FUNCTION=>
*1 SET NO      NEXT POWER ON RESET NO. => 0          CURRENT NO. = 0
*2 PROTECT    SPECIFY P(PROTECT) OR U(UNPROTECT)
*3 SWAP       SPECIFY SWAP NO.          <=>
*4 SAVE       SAVE NO. OR A(ALL)      =>          *PF8 NEXT PAGE
*5 RESTORE    RESTORE NO.              =>

CL-0      CPU-0 IOP-0      RUN

CE      TEST
    
```

Figure 18: AUXILIARY FRAME: IORSF CONTROL screen

The IORSF files are displayed in this frame. The file number of the current IORSF is displayed in the `CURRENT NO. =` field.

When you select a function and press the ENTER key, parameters are requested in the other input fields. Once you have entered the parameters and pressed the ENTER key, the functions for the IORSF files are executed.

FUNCTION => The following function is selected after the corresponding number has been entered:

1	SET NO	selects an IORSF. Entry of the set number in the <code>NEXT POWER ON RESET NO. =></code> field. For activation, an IMPL is required (see AU4 frame on “(AU4) AUXILIARY FRAME: POWER STAND-BY/IMPL”).
2	PROTECT	engages/disengages IORSF protection from being overwritten: After selecting function 2, enter <code>P</code> (Protect) or <code>U</code> (Unprotect) before the appropriate number
3	SWAP	swaps two IORSFs: enter the numbers in the <code>SPECIFY SWAP NO. 'blank' 'blank' <=> 'blank' 'blank'</code> fields.
4	SAVE	saves one or all IORSFs: enter the number or the value <code>A</code> (All) in the field <code>SAVE NO. OR A(ALL) ==> 'blank'</code>
5	RESTORE	restores an IORSF: enter the numbers in the field <code>RESTORE NO. ==> 'blank'</code>

NEXT POWER ON RESET NO. => Enter the number of the IORSF file which is to be activated after the next IMPL. You can only make an entry if you select function 1 beforehand.

SPECIFY SWAP NO.

'blank' 'blank' <=>

'blank' 'blank'

Enter the numbers of two IORSF files which are to be swapped. You can only make entries if you select function 3 beforehand.

SAVE NO. OR A(ALL) ==>

'blank'

Specify the number of the IORSF file which is to be saved. Specifying "A" saves all IORSF files. You can only make entries if you select function 4 beforehand.

RESTORE NO. ==> 'blank'

Specify the number of the IORSF file which is to be restored. You can only make entries if you select function 5 beforehand.

Frame-specific functions

Page down (PF8) Sets 4 to 7 are displayed

Page up (PF7) Sets 0 to 3 are displayed

3.4.8.3 (AU3) AUXILIARY FRAME: RELATED SCB'S

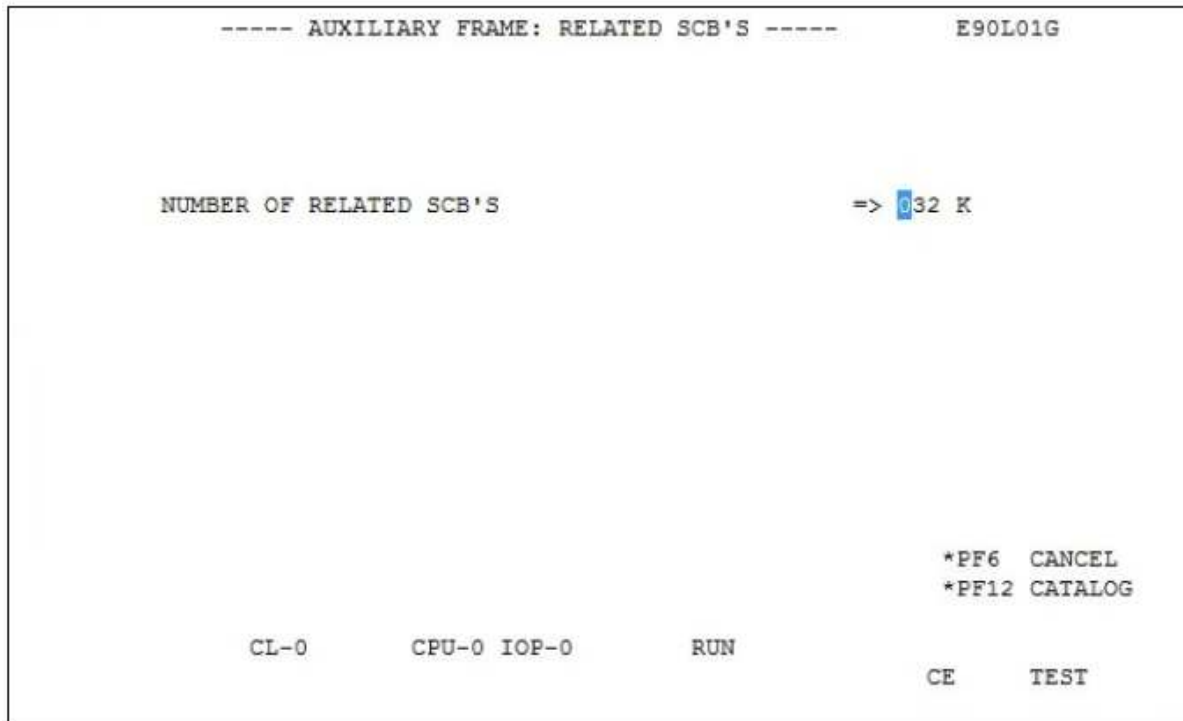

Figure 19: AUXILIARY FRAME: RELATED SCB'S screen

i Changes in this frame are reserved for the Customer Support.

3.4.8.4 (AU4) AUXILIARY FRAME: POWER STAND-BY/IMPL

```

----- AUXILIARY FRAME: POWER STAND-BY/IMPL ----- E90L01G

          FUNCTION=>
            *1 POWER STAND-BY
            *2 IMPL

          CL-0          CPU-0 CHP-0          RUN
RA                                     []-[ ]00
    
```

Figure 20: AUXILIARY FRAME: POWER STAND-BY/IMPL screen

By making an entry in this frame and pressing the ENTER key, you can switch the server off or re-initialize it.

FUNCTION => The following function is selected after the corresponding number has been entered:

1	POWER STAND- BY	switches the Server Unit off; order: first devices connected to the PCI (Power Control Interface), then the servers (for further information on this see “Switching the SE /390 on and off” in the Basic Operating Manual [1])
2	IMPL	executes IMPL

After you have selected a function and pressed the ENTER key, the following prompt will appear:

```

*****
*
* ARE YOU SURE ? (ENTER Y OR N) N *
*
*****
    
```

! CAUTION!
 POWER STAND-BY or IMPL may not be executed during system operation! If this instruction is not heeded, BS2000 will be aborted!

- > Press the Y and ENTER keys to switch off the system or to execute an IMPL, or the N and ENTER keys to cancel the procedure.

3.4.8.5 (AU5) AUXILIARY FRAME: LOAD PRESET1

```

----- AUXILIARY FRAME: LOAD PRESET1 -----          E90L01G
-START MODE-
==> 1
>1 START AUTO          1 PRESET GROUP -----+
*2 START FAST          2 CURRENT GROUP -----+ |
*3 START DIAL          3 UNIT ADDRESS -+      +      +
*4 START               A108      A108      A108
                       XXXX      XXXX
                       XXXX      XXXX
                       XXXX      XXXX

                                           -POWER ON IPL-
                                           ==> 2
                                           *1 ENABLE
                                           >2 DISABLE

-INITIAL FRAME-
==> 2
*1 LOAD FRAME(BASIC)          *PF12 CATALOG
>2 LOAD FRAME(DETAIL)        *PF9  GO TO LOAD PRESET-2
      CL-0      CPU-0 CHP-0      RUN
RA                                     []-[ ]00
    
```

Figure 21: AUXILIARY FRAME: LOAD PRESET1 screen

You can predefine the execution of an IPL by making an entry in this frame and clicking on PF12.

START MODE ==> Predefine the loading mode by entering the appropriate number and comment for the BS2000 loading mode:

1	START AUTO	for automatic startup
2	START FAST	for fast startup
3	START DIAL	for dialog startup
4	START	not used

IPL DEVICE Entries in this field specify from which device an IPL should be executed.

1	PRESET GROUP	Up to four unit addresses can be entered in the input field for PRESET GROUP. The operating system is loaded from the first device (IPL). In the case of an error, the IPL is executed by the next device listed.
---	---------------------	---

POWER ON IPL Here you determine the behavior of the SVP after switching on.

==>

1	ENABLE	automatically executes IPL after IMPL
---	--------	---------------------------------------

2	DISABLE	does not execute IPL, i.e. IPL must be triggered manually using PROGRAM LOAD FRAME: BASIC or PROGRAM LOAD FRAME: DETAIL-1
----------	---------	---

INITIAL FRAME Here you can set the display form of the PROGRAM LOAD FRAME.

==>

1	LOAD FRAME (BASIC)	PROGRAM LOAD FRAME: BASIC (see “(LD) PROGRAM LOAD FRAME: BASIC”)
2	LOAD FRAME (DETAIL)	PROGRAM LOAD FRAME: DETAIL-1 (see “(LD) PROGRAM LOAD FRAME: DETAIL-1”)

Frame-specific functions

PF12 Storing settings

PF9 switches to the LOAD PRESET2 screen

```

----- AUXILIARY FRAME: LOAD PRESET2 ----- E90L01G
-VM MODE-
==> 2
*1 NATIVE
>2 AVM/EX

-START IPL NO-
==> 1
>1 FIX(1)
*2 CURRENT

                                *PF12  CATALOG
                                *PF9   GO TO LOAD PRESET-1
                                RUN
                                CL-0    CPU-0 CHP-0
                                0
RA                                []-[ ]00

```

Figure 22: AUXILIARY FRAME: LOAD PRESET2 screen

You can set the operation mode by making an entry in this frame and clicking on PF12.

VM MODE ==> Selection of the firmware to be loaded from SVP

1	NATIVE	for BS2000 operation
----------	--------	----------------------

2	AVM/EX	for VM2000
---	--------	------------

START IPL NO ==> Selection of the IPL Start Mode number

1	FIX(1)	Start Mode number 1 (automatic start)
2	CURRENT	not used on the Server Unit

Frame-specific functions

PF12 Storing settings

PF9 switches to the LOAD PRESET1 screen

3.4.9 (MF) MSF FRAME

```

----- MSF FRAME: FLAG CODE LOG DISPLAY -----          E90L01G
INITIALIZED 2010.03.11 15:43:23
LAST SEQ 0538
                                         NODE:SELF
                                         1/14
SEQ   UNIT   FLAG CODE   DATE   TIME   CT   KIND   LINK INFORMATION
*0538  ICC   A9 7M12 3C 006D2H00 03.16 16:50:42   ATTN   HC27 SP4
      AW 026D 0C 006D0H00
*0537  ICC   A9 7M12 3C 00692H00 03.16 16:50:34   ATTN   HC26 SP3
      AW 0269 0C 00690H00
*0536  ICC   A9 7M12 3C 002D2H00 03.16 16:50:28   ATTN   HC25 SP2
      AW 022D 0C 002D0H00
*0535  ICC   A9 7MC4 3C 00642H00 03.16 16:50:18   ATTN   HC24 SP1
      AW XX64 0C 00640H00
*0534  ICC   A9 7MC1 3C 00642H00 03.16 16:50:12   ATTN   HC23
      AW XX64 0C 00640H00
*0533  ICC   A9 7M12 3C 00292H00 03.16 16:42:39   ATTN   HC22
      AW 0229 0C 00290H00
*0532  ICC   A9 7M12 3C 006D2H00 03.16 16:42:33   ATTN   HC21
      AW 026D 0C 006D0H00

          PF1:HELP  PF7:PREV PAGE PF8:NEXT  PAGE
          CL-0      CPU-0 CHP-0      RUN
          FLAG CODE = A97M123C 006D2H00
RA
          []-[ ]00

```

Figure 23: MSF FRAME: FLAG CODE LOG DISPLAY screen

The SVP logs all FLAG codes. The FLAG codes are displayed when this frame is invoked. As from a certain priority, the FLAG codes are displayed in frame line 24.

Frame-specific functions

PF1 help function

Page up one page backwards, in the direction of the newer entries

Page down one page forwards, in the direction of the older entries

i This frame is intended for use by Customer Support.

You only reach FLAG CODE LOG DISPLAY via a subframe (call FR MF with Function -> L1) and then <L1>.

3.4.10 (PA) PERFORMANCE ANALYZER FRAME

```
----- PERFORMANCE ANALYZER FRAME ----- E90L01G
FUNCTION =>                                STATUS DISABLE / STOP
1 ENABLE & ITEM SELECT                      LOGGING STOP
2 DISABLE
3 START & DISPLAY                          ----- CH BUSY LEVEL -----
4 START & CH BUSY                          0 < GREEN < 30 (%)
5 STOP                                      31 < WHITE < 100 (%)
6 LOGGING START
7 LOGGING STOP                             ----- INTERVAL TIME -----
8 CPU LOG DISPLAY                          SAMPLING ==> 2 SEC.
9 CH LOG DISPLAY                           LOGGING ==> 1 MIN.

RA                CL-0                CPU-0 CHP-0                RUN                []-[ ]00
```

Figure 24: PERFORMANCE ANALYZER FRAME screen



The PA frame is not intended for use.

3.5 Examples of SVP operation

This chapter contains examples of the following tasks:

- [Selecting IORSF](#)
- [Activating IORSF](#)
- [Setting up PROGRAM LOAD FRAME PRESET1](#)
- [Setting up PROGRAM LOAD FRAME PRESET2](#)
- [Executing IPL in PROGRAM LOAD FRAME: DETAIL-1](#)
- [Setting operating mode via PROGRAM LOAD FRAME: DETAIL-2](#)

3.5.1 Selecting IORSF

The steps described below are required to load a specific IORSF the next time IMPL takes place or the next time the system is switched on.

IOVSF with Level 2 is selected in the example below.

Requirement

You are logged in to the SE Manager and have opened the SVP console.

i A BS2000 operator account has access to the SVP console if its individual right permits SVP access.

The MODE SELECTION FRAME is displayed on the screen:

```

----- MODE SELECTION FRAME -----          E90L01G
FUNCTION=>
- EXECUTION -          - SELECTION -          CPU SELECT=>
- 0 1 2 3 4          -          -
*1 CPU STOP          *LD PROGRAM LOAD          -          -
*2 INTERRUPT          *ST STATUS DISPLAY
*3 TOD ENABLE          *MA MANUAL OPERATION          STOP/START MODE=>
*4 SYSTEM RESET          *AD ALTER/DISPLAY
*5 SYSTEM RESET CLEAR  *ME MESSAGE          *1 ALL CPU
*6 STORE STATUS          *CH CH/SUBCH STATUS          >2 TARGET CPU
*7 RESTART          *AU AUXILIARY
*MF MSF
*PA PERFORMANCE ANALYZER

          CL-0          CPU-0 CHP-0          RUN
RA          []-[ ]00
    
```

Figure 25: MODE SELECTION FRAME screen

Invoke the AUXILIARY FRAME: MENU screen

- > Enter AU in the FUNCTION=> field and then press the ENTER key,

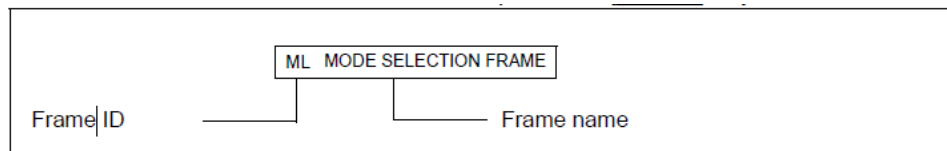

or

- > enter the FR AU command in line 24 and press the ENTER key.
The AUXILIARY FRAME: MENU screen is displayed:

```
----- AUXILIARY FRAME: MENU ----- E90L01G  
  
SELECTION=> █  
  
*1 REAL CLOCK  
*2 IORSF CONTROL  
*3 RELATED SCB  
*4 POWER STAND-BY/IMPL  
*5 LOAD PRESET  
*6 POWER SCHEDULE  
  
CL-0      CPU-0 IOP-0      RUN      CE      TEST
```

Figure 26: AUXILIARY FRAME: MENU screen

Invoking IORSF Control Frame

- > Enter 2 in the SELECTION=> field. Press the ENTER key.

i If the frame code AU2 is entered in the MODE SELECTION FRAME or the FR AU2 command is entered in line 24, the following frame is displayed immediately.

The AUXILIARY FRAME: IORSF CONTROL screen is displayed:

```

----- AUXILIARY FRAME: IORSF CONTROL -----          E90L01G

NO.  COMMENT
0    SU700001SU700-29001 / DISK DET. DX600-AENDERUNG / 13.11.14
      DATE 2014.11.13      TIME 09:07      TYPE-1
1    SU700001SU700-29001 / ERW. DX440-S2-1 AUF 256 DVC / 04.08.14
      DATE 2014.10.21      TIME 15:41      TYPE-1
2    SU700001SU700-29001 / ALLE PLATTEN ATTACHED / 05.11.14
      DATE 2014.11.05      TIME 13:42      TYPE-1
3    SU700001SU700-29001 / ERW. DVC F6E0 BIS F6EF / 21.10.14
      DATE 2014.10.21      TIME 13:33      TYPE-1

FUNCTION=>
*1 SET NO      NEXT POWER ON RESET NO. => 0          CURRENT NO. = 0
*2 PROTECT    SPECIFY P(PROTECT) OR U(UNPROTECT)
*3 SWAP      SPECIFY SWAP NO.          <=>
*4 SAVE      SAVE NO. OR A(ALL)      =>          *PFS NEXT PAGE
*5 RESTORE   RESTORE NO.             =>
            CL-0      CPU-0 IOP-0      RUN          CE      TEST

```

Figure 27: AUXILIARY FRAME: IORSF CONTROL screen

The first four IORSFs are displayed in the upper portion of the screen. You can scroll to the next four IORSFs with the *Page down* key, and back with the *Page up* key.

In this example the IORSF with the number 0 is active.

Display: CURRENT NO. = 0

Now you want to activate the IORSF with the number 2:

- > Enter 1 in the FUNCTION=> field. Press the ENTER key.
- > For our example enter 2 in the NEXT POWER ON RESET NO. field and press the ENTER key.

3.5.2 Activating IORSF

The set IORSF must be activated with an IMPL:

Requirement

You are in the AUXILIARY FRAME: IORSF CONTROL.

- > Click on *Return* to switch back to the AUXILIARY FRAME: MENU.
- > Enter 4 in the SELECTION=> field. Press the ENTER key.

The AUXILIARY FRAME: POWER STAND-BY/IMPL screen is displayed:

```

----- AUXILIARY FRAME: POWER STAND-BY/IMPL ----- E90L01G
      FUNCTION=> 2
      *1 POWER STAND-BY
      *2 IMPL

      CL-0          CPU-0 CHP-0          RUN

RA                                                    [ ]-[ ]00

```

Figure 28: AUXILIARY FRAME: POWER STAND-BY/IMPL screen

- > Enter 2 in the FUNCTION=> field to execute an IMPL. Press the ENTER key.

The following prompt appears on the screen:

```

*****
*
* ARE YOU SURE ? (ENTER Y OR N) N *
*
*****

```

! CAUTION!

The IMPL must not be executed during system operation! If this instruction is not heeded, BS2000 will be aborted!

- > Press the Y key to execute the IMPL or the N key to cancel the procedure. Confirm your entry with the ENTER key.

3.5.3 Setting up PROGRAM LOAD FRAME PRESET1

In this example, you specify:

- LOAD function 1 with the name AUTO (AUTO=Automatic Startup) for a POWER ON IPL
- Device number of the IPL device to be used for a POWER ON IPL (currently A108)
- Automatic IPL after a POWER ON
- The LOAD FRAME should always be displayed as PROGRAM LOAD FRAME: DETAIL-1.

Requirement

You have opened the SVP window and set up the connection to the SVP console.

The MODE SELECTION FRAME is displayed on the screen (see [“Selecting IORSF”](#)).

Invoke the AUXILIARY FRAME: LOAD PRESET1 screen

- > Enter AU in the FUNCTION=> field and then press the ENTER key,
or
- > enter the `FR AU` command in line 24 and press the ENTER key.

The AUXILIARY FRAME: MENU screen is displayed (see [“Selecting IORSF”](#)).

- > Enter 5 in the SELECTION=> field. Press the ENTER key.

The AUXILIARY FRAME: LOAD PRESET1 screen is displayed:

```

----- AUXILIARY FRAME: LOAD PRESET1 -----      E90L01G
-START MODE-                -IPL DEVICE-
==> 1
>1 START AUTO                1 PRESET GROUP -----+
*2 START FAST                 2 CURRENT GROUP -----+
*3 START DIAL                 3 UNIT ADDRESS  +-+
*4 START                      A108      A108      A108
                                XXXX      XXXX
                                XXXX      XXXX
                                XXXX      XXXX

                                -POWER ON IPL-
                                ==> 1
                                *1 ENABLE
                                >2 DISABLE

-INITIAL FRAME-
==> 2
*1 LOAD FRAME(BASIC)          *PF12 CATALOG
>2 LOAD FRAME(DETAIL)         *PF9 GO TO LOAD PRESET-2

RA                CL-0                CPU-0 CHP-0                RUN                []-[ ]00
    
```

Figure 29: AUXILIARY FRAME: LOAD PRESET1 screen

i You can reach this screen directly from the MODE SELECTION FRAME by entering the frame code AU5 in the FUNCTION=> field or the command FR AU5 in line 24 and pressing the ENTER key.

START MODE ==>	Enter 1 for automatic start of BS2000
IPL DEVICE	
PRESET GROUP	A unit address from which the operating system is loaded (IPL) must be entered in the input field for PRESET GROUP. A maximum of three further addresses can be entered. Entry in this example: A108.
POWER ON IPL ==>	Enter 1 for automatic IPL after POWER ON
INITIAL FRAME ==>	Enter 2 for a detailed display of the LOAD FRAME

Store parameters

- > Click on PF12

The values entered are saved and thus made known to the SVP. These settings are accessed for each IPL.

3.5.4 Setting up PROGRAM LOAD FRAME PRESET2

In the PROGRAM LOAD FRAME PRESET2 you specify which operating mode is to be set after the server is switched on.

The following are specified in the example below:

- VM2000 operating mode
- Automatic startup of the operating system

Requirement

You are in the AUXILIARY FRAME: LOAD PRESET1.

Invoke the AUXILIARY FRAME: LOAD PRESET2 screen

- > Click on PF9.

The AUXILIARY FRAME: LOAD PRESET2 screen is displayed:

```

----- AUXILIARY FRAME: LOAD PRESET2 ----- E90L01G

-VM MODE-
==> 2
>1 NATIVE
*2 AVM/EX

-START IPL NO-
==> 1
>1 FIX(1)
*2 CURRENT

*PF12 CATALOG
*PF9 GO TO LOAD PRESET-1

CL-0 CPU-0 CHP-0 RUN

RA [ ]-[ ]00
    
```

Figure 30: AUXILIARY FRAME: LOAD PRESET2 screen

VM MODE ==>	Enter 2 for VM2000 operation
START IPL NO ==>	Always enter 1 for automatic startup

Store parameters

- > Click on PF12

The values entered are saved and thus made known to the SVP. These settings are accessed for each IPL.

3.5.5 Executing IPL in PROGRAM LOAD FRAME: DETAIL-1

The IPL can be executed manually according to the setting using PROGRAM LOAD FRAME DETAIL-1.

The following are specified in the example below:

- loading VM2000
- dialog startup
- IPL device is specified manually by the entry of the unit address
(here: loading the VM2000 from a device with the unit address A108)

Requirement

You are in the AUXILIARY FRAME: LOAD PRESET2 screen.

Invoke the PROGRAM LOAD FRAME: DETAIL-1 screen

- > Click on ModSel to return to the MODE SELECTION FRAME.
- > Enter the frame code `LD` and press the ENTER key.
Or enter the `FR LD` command in line 24 and press the ENTER key.

i After entering `LD` or `FR LD` in the MODE SELECTION FRAME, depending on the INITIAL FRAME setting in the AUXILIARY FRAME: LOAD PRESET1 screen (see [“Setting up PROGRAM LOAD FRAME PRESET1”](#)) one of the following screens is displayed:

- PROGRAM LOAD FRAME: DETAIL-1 screen
- PROGRAM LOAD FRAME: BASIC screen

In the example the PROGRAM LOAD FRAME: DETAIL-1 is displayed:

```

----- PROGRAM LOAD FRAME: DETAIL-1 ----- E90L01G

-LOAD FUNCTION-          -IPL DEVICE-
==>                      ==> 2
*1 START AUTO            *1 PRESET GROUP -----+
*2 START FAST            >*2 CURRENT GROUP -----+      |
*3 START DIAL            *3 UNIT ADDRESS  -+      +      +
*4 START                  A108      A108      A108
*5 SYSTEM DUMP                                XXXX      XXXX
*6 LOAD CLEAR -----+                        XXXX      XXXX
*7 LOAD NON CLEAR --+                          XXXX      XXXX
|
+MT CONTROL-          --- DETAIL-2 STATUS ---
PARMS=>               ==> 1          VM MODE : NATIVE
>*1 NL                EXA MODE : ENABLE
*2 SL                IPL EXEC : ENABLE
*3 NL-REWIND
*4 SL-REWIND          *ENTER EXECUTE
                    *PF3 GO TO BASIC FRAME
                    *PF9 GO TO DETAIL-2

CL-0          CPU-0 CHP-0          RUN

RA                                                    [ ]-[ ]00

```

Figure 31: PROGRAM LOAD FRAME: DETAIL-1 screen

Before completing this frame, check whether the correct firmware for operating Native BS2000 or VM2000 has been loaded by the SVP. Information on this is provided in the DETAIL-2 STATUS field.

DETAIL-2 STATUS

The settings in DETAIL-2 FRAME are displayed here.

Check the settings. If the settings are correct, complete this frame and execute the Initial Program Load by pressing the ENTER key.

If the settings are not correct, correct them in DETAIL-2 FRAME (see below).

In our example VM MODE: NATIVE, i.e. the firmware for BS2000 operation, is loaded. This setting must be changed in DETAIL-2 FRAME for this example.

Swap to PROGRAM LOAD FRAME: DETAIL-2

For this example, go to the [section “Setting operating mode via PROGRAM LOAD FRAME: DETAIL-2”](#) and continue there.

If the DETAIL-2 STATUS is correct, fill in the entry fields as follows:

```

----- PROGRAM LOAD FRAME: DETAIL-1 -----          E90L01G
-LOAD FUNCTION-                -IPL DEVICE-
==> 3                          ==> 3
*1 START AUTO                  *1 PRESET GROUP -----+
*2 START FAST                  >*2 CURRENT GROUP -----+   |
*3 START DIAL                  *3 UNIT ADDRESS  -+      +      +
*4 START                       A108    A108    A108
*5 SYSTEM DUMP                 XXXX    XXXX    XXXX
*6 LOAD CLEAR -----+        XXXX    XXXX
*7 LOAD NON CLEAR  -+        XXXX    XXXX
|
+MT CONTROL-                  --- DETAIL-2 STATUS ---
PARMS=> 1                      ==> 1
>*1 NL                        VM  MODE : AVM/EX
*2 SL                          EXA  MODE : ENABLE
*3 NL-REWIND                   IPL  EXEC : ENABLE
*4 SL-REWIND                   *ENTER EXECUTE
                                *PF3   GO TO BASIC FRAME
                                *PF9   GO TO DETAIL-2

CL-0          CPU-0 CHP-0          RUN

RA                                                    []-[ ]00

```

Figure 32: PROGRAM LOAD FRAME: DETAIL-1 screen

LOAD FUNCTION ==>	Enter 3 for a dialog start
IPL DEVICE ==>	Enter 3 for entry of a device address
UNIT ADDRESS	The device address of the load device can be entered in this field In this example, the previous IPL was executed successfully from the current device with device address A108. Thus the desired address is already in the UNIT ADDRESS field. It was also entered in the CURRENT GROUP field by the SVP. Entering a 2 in the IPL DEVICE field loads the operating system from the desired device.
PARMS =>	Enter 1 in the first position of the field to load VM2000
MT CONTROL ==>	1 is the default. This parameter is only important for loading from tape.

Execute IPL

- > Press the ENTER key after you have checked all the settings.

The following prompt appears on the screen:

```
*****  
*  
* ARE YOU SURE ? (ENTER Y OR N) N *  
*  
*****
```

! CAUTION!

The IPL must not be executed during system operation! If this instruction is not heeded, BS2000 will be aborted!

- > Press the Y key to execute the IPL, or the N key to cancel the procedure. Confirm your entry with the ENTER key.

3.5.6 Setting operating mode via PROGRAM LOAD FRAME: DETAIL-2

The operating mode can be set anew according to the setting using PROGRAM LOAD FRAME: DETAIL-2. This selects the appropriate firmware for running BS2000 or VM2000.

The following are specified in the example below:

- VM2000 operating mode
- executing IPL after reloading the firmware

Requirement

You are in the PROGRAM LOAD FRAME: DETAIL-1 screen.

Invoke the PROGRAM LOAD FRAME: DETAIL-2 screen

- Click on PF9

The PROGRAM LOAD FRAME: DETAIL-2 screen is displayed:

```

----- PROGRAM LOAD FRAME: DETAIL-2 -----          E90L01G

-VM MODE-                                           -IPL EXECUTION-
==> 2                                               ==> 1
>*1 NATIVE                                         >*1 ENABLE
*2 AVM/EX                                         *2 DISABLE

                                           *ENTER EXECUTE
                                           *PF3   GO TO BASIC FRAME
                                           *PF9   GO TO DETAIL-1

CL-0          CPU-0 CHP-0          RUN

RA                                                    []-[ ]00
    
```

Figure 33: PROGRAM LOAD FRAME: DETAIL-2 screen

VM MODE ==>	Enter 2 for VM2000 operation
IPL EXECUTION ==>	Enter 1 for executing IPL

Storing settings

- After you have checked all the settings, click on PF9 to store them and to switch to PROGRAM LOAD FRAME: DETAIL-1.

The new setting is displayed under VM MODE: in the DETAIL-2 STATUS field. VM MODE: AVM/EX is now displayed. The firmware is relocated before the IPL is executed.

By filling PROGRAM LOAD FRAME: DETAIL-1 and pressing ENTER you can execute the IPL (see [“Executing IPL in PROGRAM LOAD FRAME: DETAIL-1”](#)).

Make sure you fill in the PARMS field correctly.

4 HNC (High-speed Net Connect)

The High-speed Net Connect (HNC for short) connects the Server Unit /390 to the LAN. Furthermore, as net client the HNC permits access to the Net-Storage. The HNC is managed using the SE Manager.

The internal disks, power supply units, and fans are redundant in design and can be replaced during ongoing operation.

The rack console serves as a monitor for the Management Unit and consequently as a local access to the administrative and operating functions of the SE server. When necessary (in the event of maintenance), the rack console can also be attached to the HNC using the KVM switch.

The HNC software is preinstalled ex works.

HNC redundancy is possible as an option. Up to four HNCs can be connected to an SU /390.

Detailed information on operating the HNC is provided in the "Operation and Administration" manual [7].

Detailed information on the various hardware components and interfaces of the HNC is provided in the data sheet "Fujitsu Server BS2000 SE Series".

See the product site for the relevant server at <http://www.fujitsu.com>:

- > Go to *Products* -> *Servers* -> *BS2000* -> *Fujitsu Server BS2000* and select SE710/SE730/SE730B/SE740.

4.1 Front of the HNC

Depending on the model of the SE server, different HNC variants are available: HNC M3 in SE710, HNC M4 in SE730, HNC M5 in SE730B resp. HNC M6 in SE740.

HNC M3



Figure 34: HNC M3 (SE710) - front

Indicators on the front panel of HNC M3

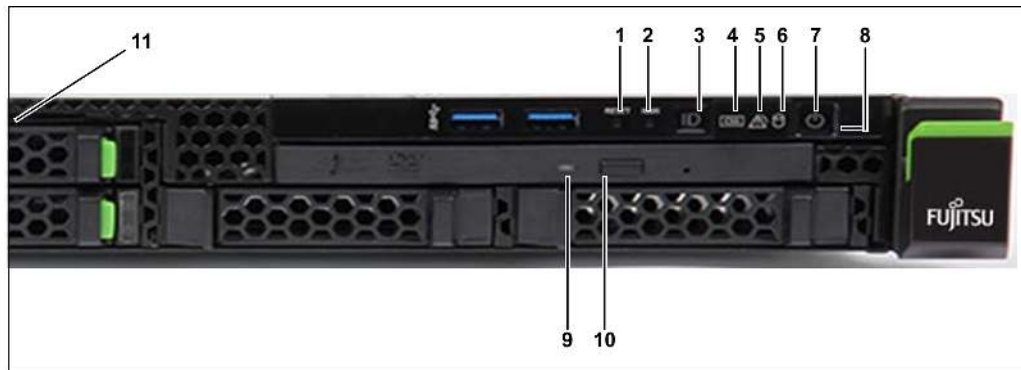

Figure 35: HNC M3 (SE710) - front panel

No.	Meaning
1	Reset button (for Customer Support only)
2	NMI button (for Customer Support only)
3	ID button / ID indicator
4	CSS indicator (orange); notify Customer Support
5	Global error indicator (orange); notify Customer Support
6	HDD/SSD activity indicator
7	On/Off button / Status indicator
8	Status indicator (power cable connected); next to the On/Off switch
9	Optical drive activity indicator
10	Open/close optical drive
11	ID card (green); further left, above HDD module

HNC M4, HNC M5 and HNC M6

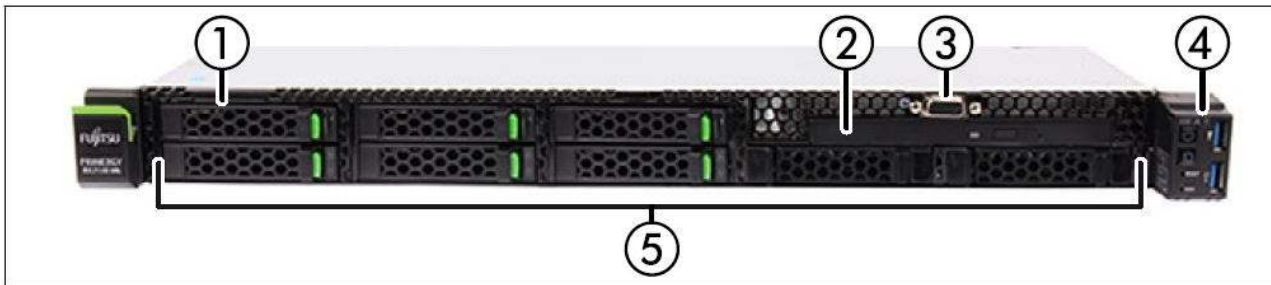

Figure 36: HNC M4 / HNC M5 / HNC M6 (SE730 / SE730B / SE740) - front

No.	Meaning
1	ID card
2	Optical disk drive
3	VGA port
4	Operation panel (see figure 38)
5	HDDs / SSDs

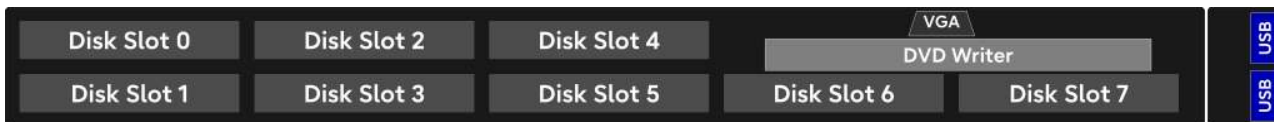

Figure 37: HNC M4 / HNC M5 / HNC M6 (SE730 / SE730B / SE740) - front scheme

Indicators on the front panel of HNC M4 / HNC M5 / HNC M6

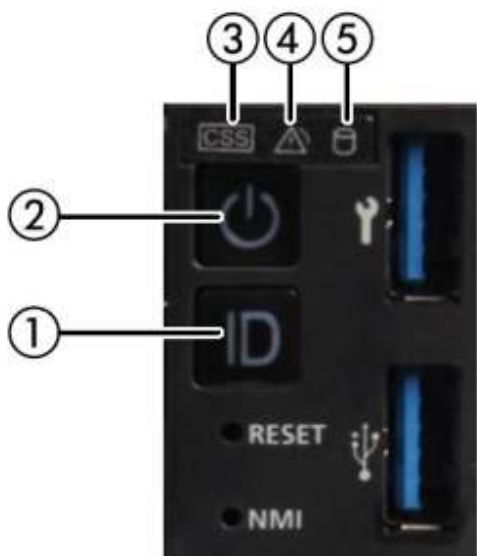





Figure 38: HNC M4 / HNC M5 / HNC M6 (SE730 / SE730B / SE740) - front panel

Pos.	Label	Key / Display	Function	Status
1	ID	ID button / ID indicator	Identifies the ID display on the front panel and at the I/O panel for an easier server identification.	blue on
2		On/Off button	Switch on server: Off / Server switched on / BMC firmware starting after connection to power grid	off / green on / green flashing slowly
3		CSS display	Notify Customer Support if on or flashing	off / orange / orange flashing
4		Global error display	Notify Customer Support if on or flashing	off / orange / orange flashing
5		HDD/SSD activity indicator	Data access running	green flashing
	RESET	Reset button	System restart (for Customer Support only)	
	NMI	NMI button	For Customer Support only	

Optical drive and USB interfaces



The DVD-RW drive is used by Customer Support to install and update the HNC software.

Use of the USB interfaces is reserved for Customer Support.

4.1.1 Controls

<p>ID</p>	<p>Identification (ID) button</p> <p>Lights up (blue) on the front and on the rear of the HNC when the ID button is pressed. The two ID indicators are synchronized.</p>
	<p>On/Off button</p> <p>When the HNC is switched off, it is switched on again by pressing the On/Off button once.</p> <p>When the HNC in is in operation, it is switched off by pressing the On/Off button once.</p> <div data-bbox="266 548 1455 680" style="background-color: #fff9c4; padding: 5px;"> <p>! CAUTION!</p> <p>Possible loss of data!</p> </div> <div data-bbox="266 709 1455 821" style="background-color: #e1eef6; padding: 5px;"> <p>i The On/Off switch does not disconnect the server from the voltage grid. To disconnect from the mains completely, remove the power plugs.</p> </div>
<p>RESET</p>	<p>Reset button</p> <p>Pressing the Reset button reboots the HNC.</p> <div data-bbox="266 989 1455 1121" style="background-color: #fff9c4; padding: 5px;"> <p>! CAUTION!</p> <p>Possible loss of data!</p> </div>
<p>NMI</p>	<p>NMI button</p> <div data-bbox="266 1241 1455 1373" style="background-color: #fff9c4; padding: 5px;"> <p>! CAUTION!</p> <p>Do not press! Possible loss of data! The NMI button may only be used by Customer Support.</p> </div>

Indicators on the operating panel

	<p>Power-on indicator (white, green)</p> <p>Lights up white when the HNC is switched off but line voltage is present. For HNC M3 the power indicator stays dark in this case but the status indicator light up green instead.</p> <p>Blinks white and green alternatingly during power up delay.</p> <div style="background-color: #e6f2ff; padding: 10px; border: 1px solid #add8e6;"> <p>i If the HNC is switched off and then immediately switched on again, it is only restarted after a power up delay. This prevents a current overload, for example.</p> </div> <p>Lights up green when the HNC is switched on.</p> <p>Flashes green when the HNC has been switched on and is in standby mode or in sleep mode.</p>
	<p>Hard disk activity indicator (green)</p> <p>Flashes green when an internal hard disk drive is being accessed.</p>
<p>CSS</p>	<p>CSS and Global error indicators (yellow/orange)</p>
	<p>Generally, the states of these indicators have the following meanings:</p> <ul style="list-style-type: none"> • Do not light up when the HNC is OK. • If the event is still acute after a power failure, the indicator is activated after the restart. • Light up when a prefailure event was detected. The indicator also lights up in standby mode. • Flash when an error was detected. The indicator also flashes in standby mode. <p>Irrespective of the color, when an indicator lights up or flashes this indicates an error event. Please notify customer support.</p>
<p>ID</p>	<p>ID indicator (blue)</p> <p>Lights up blue when the HNC has been selected by pressing the ID button. To deactivate, press the button again.</p>

Optical drive activity indicator

Lights up green when the storage medium is accessed. See also [figure 35](#) resp. [38](#).

Hard disk drive resp. SSD control indicators

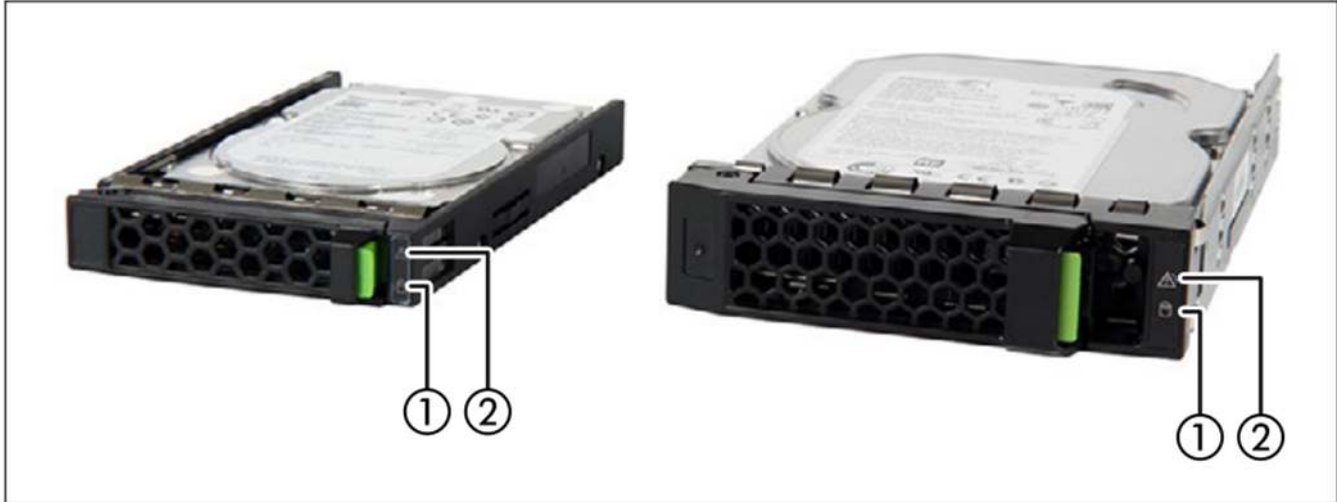

Figure 39: Front - Detailed view: Indicators on a hard disk module resp. an SSD at HNC M4 / HNC M5 / HNC M6

No.	Meaning
1	<p>HDD/SSD BUSY (green)</p> <ul style="list-style-type: none"> • Lights up: HDD/SSD in active phase • Does not light up: HDD/SSD inactive
2	<p>HDD/SSD FAULT (orange) (in conjunction with a RAID controller)</p> <ul style="list-style-type: none"> • Does not light up: no HDD/SSD error • Lights up: HDD/SSD Faulty or Rebuild Stopped (drive defective, needs replacing, a rebuild process was stopped or the HDD module/SSD is not correctly inserted) • Slow flashing: HDD/SSD Rebuild (the data is being restored after changing a hard disk drive) • Fast flashing: HDD/SSD Identify • Four fast flashes/pause: HDD/SSD Predicted Fault • Two fast flashes/pause: HDD/SSD Hot Spare (The corresponding drive has failed).

4.2 Rear of the HNC

Depending on the model of the SE server, different HNC variants are available: HNC M3 in SE710, HNC M4 in SE730, HNC M5 in SE730B resp. HNC M6 in SE740.

HNC M3



Figure 40: HNC M3 (SE710) - rear

ID/CSS/Global error indicator

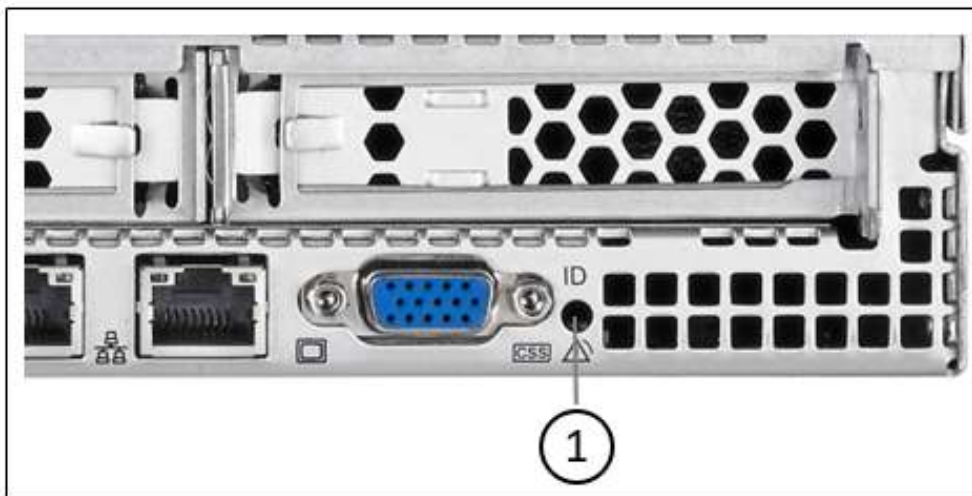



Figure 41: ID/CSS/Global error indicator (HNC M3)

No.	Meaning
1	ID/CSS/Global error indicator

Element	Meaning
ID	ID indicator (blue) Lights up blue when the HNC has been selected by pressing the ID button. To deactivate, press the button again.
CSS	CSS and Global error indicator (yellow/orange)
	<p>Generally, the states of these indicators have the following meanings:</p> <ul style="list-style-type: none"> • Do not light up when the HNC is OK. • If the event is still acute after a power failure, the indicator is activated after the restart. • Light up when a prefailure event was detected. The indicator also lights up in standby mode. • Flash when an error was detected. The indicator also flashes in standby mode. <p>Irrespective of the color, when an indicator lights up or flashes this indicates an error event. Please notify customer support.</p>

LAN indicators

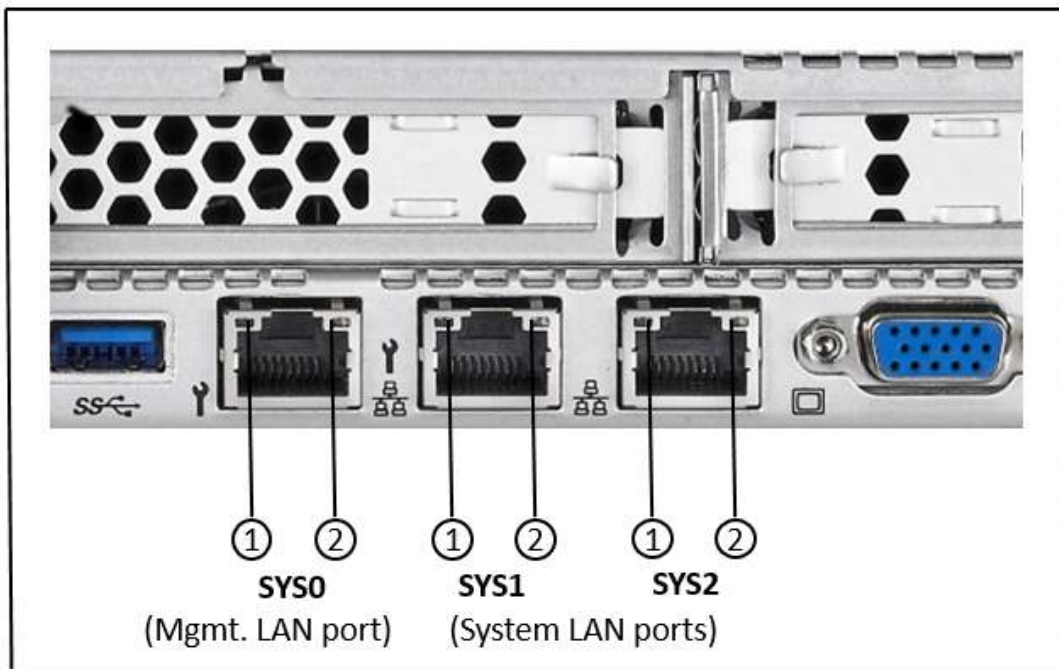

Figure 42: LAN indicators (HNC M3)

No.	Meaning
1	LAN activity indicator Lights up green if a LAN connection exists. Does not light up if no LAN connection exists. Flashes green when a LAN transfer is in progress.
2	LAN speed indicator Lights up yellow for a LAN transfer rate of 1 Gbps. Lights up green for a LAN transfer rate of 100 Mbps. Does not light up for a LAN transfer rate of 10 Mbps.

Indicator on hot-plug power supply unit

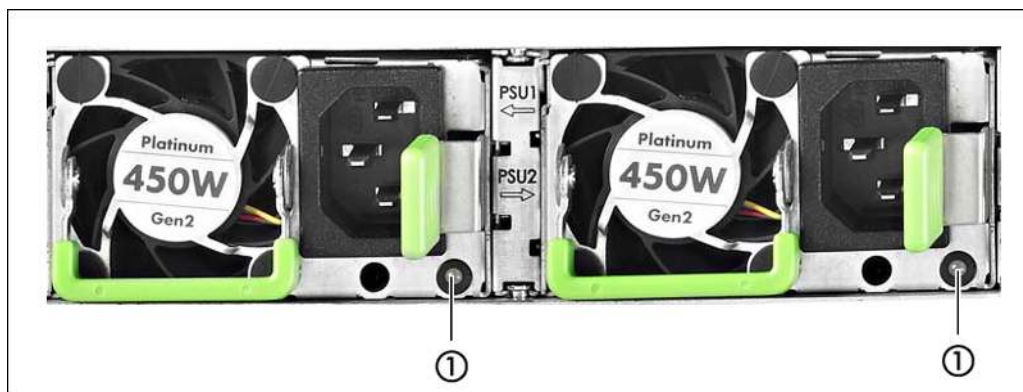

Figure 43: Indicator on hot-plug power supply unit

No.	Meaning
1	Indicator on hot-plug power supply unit (two colors) Flashes green when the HNC is switched off, but line voltage is present (standby mode). Lights up green when the HNC is switched on and functioning properly. Flashes orange when a predictable error has been detected, but the power supply unit is still running. ¹⁾ Lights up orange when no line voltage is present or the power supply unit has failed.

1) The following events are detected as predictable errors:

- The temperature is very high.
- The power consumption is very high.
- The current strength is very high.
- The fan speed is very low

In each of these cases please notify Customer Support.

PCIe slot assignment of HNC M3

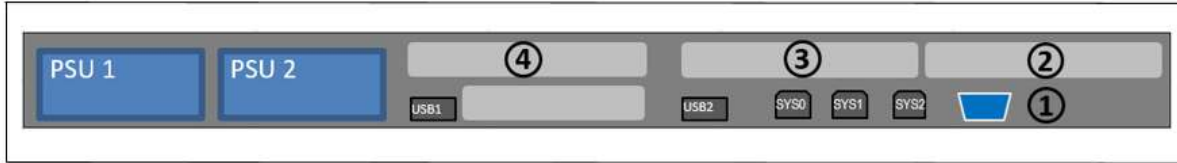

Figure 44: HNC M3 (SE710) - principle of PCIe slot assignment at the rear of the device

PCIe slot	Assignment
1	SAS RAID controller for internal HDDs
2	optional 4-port LAN card (10 GBit) with RJ45 interfaces or 4-port LAN card (10 GBit) with optical interfaces
3	FibreChannel card
4	4-port LAN card (10 GBit) with RJ45 interfaces

HNC M4

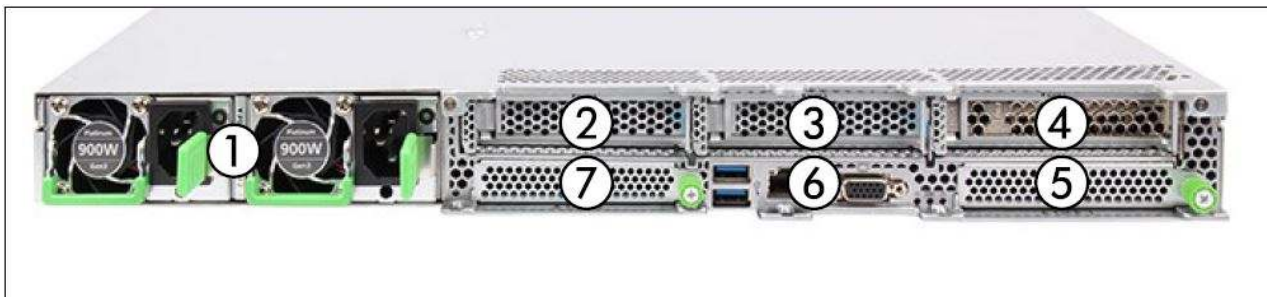

Figure 45: HNC M4 (SE730) - rear

No.	Function
1	Up to two hot-plug power supply units
2	PCIe slot 3
3	PCIe slot 2
4	PCIe slot 1
5	OCP module 1
6	I/O panel
7	OCP module 2 (unused)

PCIe slot assignment of HNC M4



Figure 46: HNC M4 (SE730) - principle of PCIe slot assignment at the rear of the device

HNC M5 / HNC M6

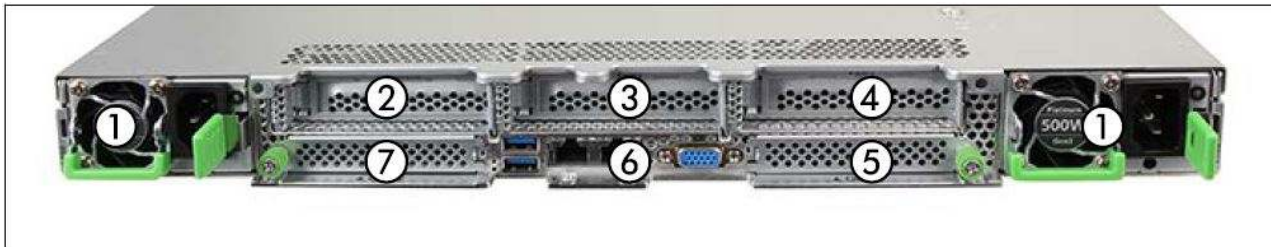

Figure 47: HNC M5 / HNC M6 (SE730B / SE740) - rear

No.	Function
1	Up to two hot-plug power supply units
2	PCIe slot 3
3	PCIe slot 2
4	PCIe slot 1
5	OCP module 1
6	I/O panel
7	OCP module 2 (generally unused; released for optional usage with X710-DA4 controller)

PCIe slot assignment of HNC M5 / HNC M6

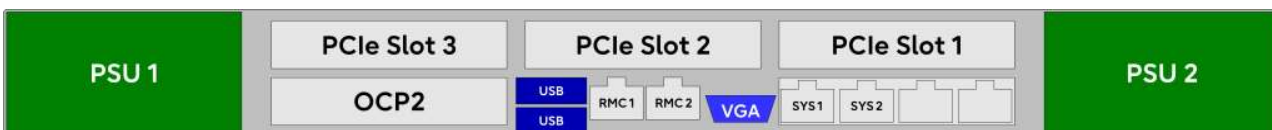

Figure 48: HNC M5 / HNC M6 (SE730B / SE740) - principle of PCIe slot assignment at the rear of the device

5 What to do if ...

In this chapter you are told how the Server Unit informs you about hardware faults and how you perform a system dump when inexplicable system downtime occurs.

In the event of hardware faults the operating system will take the necessary recovery action autonomously. Customer Service is automatically informed by means of a Service Call and initiates repair measures, possibly in conjunction with the customer.

Indicators when a hardware fault occurs

The server informs you of hardware faults in the following manner:

- On the server's control panel

When the yellow CHECK lamp lights up, this can signal a hardware fault. At the same time the status indicator displays the FLAG code. This can mean a fault in the service processor or a hardware malfunction.

- In the SVP console window

On the SVP console, indicators in row 24 of the SVP frame can signal a hardware fault. Evaluation of the FLAG code is reserved for Customer Support. The figure below shows the format of the display:

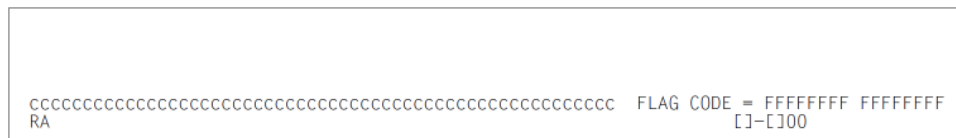

Figure 47: Status display in rows 24 and 25 of the SVP console

FLAG code `FF . . . FF` can have different meanings and consequently require different responses:

- A WRITE-CONSOLE message has been displayed. This can be deleted with `ModSel`. This does not delete the FLAG code indicator.
- A warning has been displayed, e.g. when the room temperature is too high. The cause of the fault must be rectified. System operation can continue in the meantime.
- A fault which has automatically been corrected by the hardware occurred on the server or at the interface to the peripheral devices. In this case, too, system operation can continue.
- A fault has occurred which does not permit system operation to continue. In this case you can respond as follows:

When system downtime occurs, perform an IMPL. If this does not rectify the fault, notify Customer Support and discuss how to proceed further.

Performing a system dump

Requirement:

SVP console opened and ready

1. Select (LD) PROGRAM LOAD FRAME
2. Select LOAD FUNCTION => 5 (SYSTEM DUMP)

The memory dump stored by the DUMP program to disk or tape is required for error diagnosis.

The BS2000/VM2000 system must subsequently be reloaded by means of IPL.

i Information on SLED operation is provided in the “Introduction to System Administration” manual [8].

6 Related publications

You can find the following BS2000 manuals on the manual server with the BS2000 documentation at <http://bs2manuals.ts.fujitsu.com>.

Other manuals, for example descriptions of the Fujitsu PRIMERGY and PRIMEQUEST servers, can be found on the general Fujitsu manual server at <http://manuals.ts.fujitsu.com>.

- [1] **Fujitsu Server BS2000 SE Series
Basic Operating Manual**
- [2] **Fujitsu Server BS2000 SE Series
Server Unit /390
Operating Manual**
- [3] **Fujitsu Server BS2000 SE Series
Server Unit x86
Operating Manual**
- [4] **Fujitsu Server BS2000 SE Series
Additive Components
Operating Manual**
- [5] **Fujitsu Server BS2000 SE Series
Security Manual
User Guide**
- [6] **Fujitsu Server BS2000 SE Series
Quick Guide
User Guide**
- [7] **Fujitsu Server BS2000 SE Series
Operation and Administration
User Guide**
- [8] **BS2000 OSD DX
Introduction to System Administration
User Guide**